

SERVICE & OPERATING MANUAL
Original Instructions

BRUIN PUMPS

Model S1F Metallic Design Level 1

Table of Contents

Engineering Data and Temperature Limitations 1
 Explanation of Pump Nomenclature 2
 Performance Curve 3
 Dimensions 4
 Metric Dimensions 5
 Principle of Pump Operation..... 6
 Installation and Start-Up 6
 Air Supply 6
 Air Valve Lubrication..... 6
 Air Line Moisture..... 6
 Air Inlet and Priming 6
 Between Uses 6
 Installation Guide..... 7
 Troubleshooting 8
 Warranty 8
 Recycling 9
 Important Safety Information 9
 Material Codes 10
 Composite Repair Parts Drawing 12
 Available Service and Conversion Kits 12
 Composite Repair Parts List 13
 Air Valve Drawing, Parts List, Service Instructions (Integral Muffler) 14
 Air Valve Drawing, Parts List, Service Instructions 15
 Air Valve Drawing, Parts List, Service Instructions (Cast Iron Centers Only)..... 16



See pages 2 & 30
 for ATEX ratings.

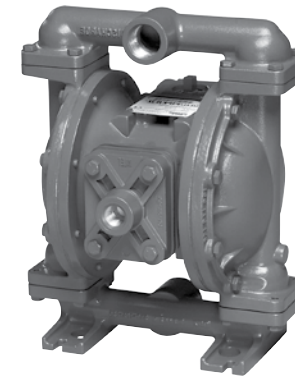

Air Valve w/Stroke Indicator Drawing, Parts List, Service Instructions 17
 Solenoid Shifted Air Valve Drawing 18
 Solenoid Shifted Air Valve Parts List 18
 Solenoid Shifted Air Valve Option 19
 Diaphragm Service Drawing, with Overlay 20
 Diaphragm Service Drawing, Non-Overlay..... 20
 Diaphragm Servicing 21
 Overlay Diaphragm Servicing 21
 Pilot Valve Servicing, Assembly Drawing & Parts List 22
 Actuator Plunger Servicing 23
 Check Valve Servicing 24
 Check Valve Drawing 24
 Optional Muffler Configurations 25
 Optional Muffler Configuration Drawing..... 25
 Pumping Hazardous Liquids..... 26
 Converting Pump for Piping Exhaust Air 26
 Converted Exhaust Illustration..... 26
 Pulse Output Kit Drawing 27
 Pulse Output Kit Options 27
 Grounding The Pump 28
 CE Declaration of Conformity Machinery 29
 CE Declaration of Conformity ATEX 30

Safety Information

! IMPORTANT



Read the safety warnings and instructions in this manual before pump installation and start-up. Failure to comply with the recommendations stated in this manual could damage the pump and void factory warranty.



When the pump is used for materials that tend to settle out or solidify, the pump should be flushed after each use to prevent damage. In freezing temperatures the pump should be completely drained between uses.

! CAUTION



Before pump operation, inspect all fasteners for loosening caused by gasket creep. Retighten loose fasteners to prevent leakage. Follow recommended torques stated in this manual.



Nonmetallic pumps and plastic components are not UV stabilized. Ultraviolet radiation can damage these parts and negatively affect material properties. Do not expose to UV light for extended periods of time.



WARNING
Pump not designed, tested or certified to be powered by compressed natural gas. Powering the pump with natural gas will void the warranty.

! WARNING



When used for toxic or aggressive fluids, the pump should always be flushed clean prior to disassembly.



Before maintenance or repair, shut off the compressed air line, bleed the pressure, and disconnect the air line from the pump. Be certain that approved eye protection and protective clothing are worn at all times. Failure to follow these recommendations may result in serious injury or death.



Airborne particles and loud noise hazards. Wear eye and ear protection.



In the event of diaphragm rupture, pumped material may enter the air end of the pump, and be discharged into the atmosphere. If pumping a product that is hazardous or toxic, the air exhaust must be piped to an appropriate area for safe containment.



Take action to prevent static sparking. Fire or explosion can result, especially when handling flammable liquids. The pump, piping, valves, containers and other miscellaneous equipment must be properly grounded.



This pump is pressurized internally with air pressure during operation. Make certain that all fasteners are in good condition and are reinstalled properly during reassembly.



Use safe practices when lifting

Grounding ATEX Pumps

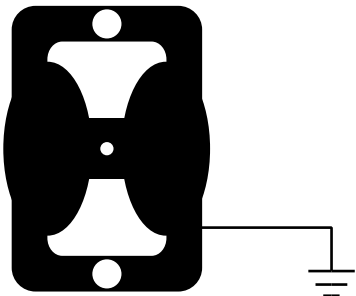

ATEX compliant pumps are suitable for use in explosive atmospheres when the equipment is properly grounded in accordance with local electrical codes. Pumps equipped with electrically conductive diaphragms are suitable for the transfer of conductive or non-conductive fluids of any explosion group. When operating pumps equipped with non-conductive diaphragms that exceed the maximum permissible projected area, as defined in EN 13461-1: 2009 section 6.7.5 table 9, the following protection methods must be applied:

- Equipment is always used to transfer electrically conductive fluids or
- Explosive environment is prevented from entering the internal portions of the pump, i.e. dry running

For further guidance on ATEX applications, please consult the factory.

Quality System
ISO9001 Certified

Environmental
Management System
ISO14001 Certified

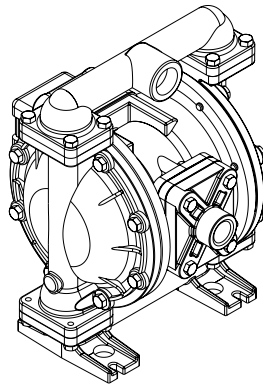

Air Inlet Side View

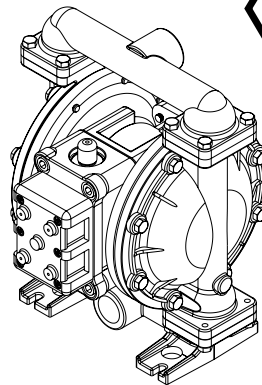

Air Exhaust Side View



See pages 2 & 30
for ATEX ratings.



BRUIN PUMPS

S1F Metallic Design Level 1 Ball Valve

Air-Operated Double Diaphragm Pump

ENGINEERING, PERFORMANCE
& CONSTRUCTION DATA

INTAKE/DISCHARGE PIPE SIZE 1" NPT (internal) 1" BSP Tapered (internal)	CAPACITY 0 to 45 gallons per minute (0 to 170 liters per minute)	AIR VALVE No-lube, no-stall design	SOLIDS-HANDLING Up to .25 in. (6mm)	HEADS UP TO 125 psi or 289 ft. of water (8.6 Kg/cm ² or 86 meters)	DISPLACEMENT/STROKE .11 Gallon / .42 liter
---	---	---	---	--	--

CAUTION! Operating temperature limitations are as follows:

Materials

	Operating Temperatures	
	Maximum	Minimum
Nitrile General purpose, oil-resistant. Shows good solvent, oil, water and hydraulic fluid resistance. Should not be used with highly polar solvents like acetone and MEK, ozone, chlorinated hydrocarbons and nitro hydrocarbons.	190°F 88°C	-10°F -23°C
EPDM Shows very good water and chemical resistance. Has poor resistance to oil and solvents, but is fair in ketones and alcohols.	280°F 138°C	-40°F -40°C
NEOPRENE All purpose. Resistant to vegetable oils. Generally not affected by moderate chemicals, fats, greases and many oils and solvents. Generally attacked by strong oxidizing acids, ketones, esters, nitro hydrocarbons and chlorinated aromatic hydrocarbons.	200°F 93°C	-10°F -23°C
PTFE Chemically inert, virtually impervious. Very few chemicals are known to react chemically with PTFE: molten alkali metals, turbulent liquid or gaseous fluorine and a few fluoro-chemicals such as chlorine trifluoride or oxygen difluoride which readily liberate free fluorine at elevated temperatures.	220°F 104°C	-35°F -37°C
FKM (Fluorocarbon) shows good resistance to a wide range of oils and solvents; especially all aliphatic, aromatic and halogenated hydrocarbons, acids, animal and vegetable oils. Hot water or hot aqueous solutions (over 70°F) will attack FKM.	350°F 177°C	-40°F -40°C
Santoprene® Injection molded thermoplastic elastomer with no fabric layer. Long mechanical flex life. Excellent abrasion resistance.	275°F 135°C	-40°F -40°C
Polypropylene A thermoplastic polymer. Moderate tensile and flex strength. Resists strong acids and alkalie. Attacked by chlorine, fuming nitric acid and other strong oxidizing agents.	180°F 82°C	32°F 0°C
Conductive HDPE	180°F 82°C	-35°F -37°C

For specific applications, always consult the BRUIN Chemical Resistance Chart

BRUIN® pumps are designed to be powered only by compressed air.

Maximum and Minimum Temperatures are the limits for which these materials can be operated. Temperatures coupled with pressure affect the longevity of diaphragm pump components. Maximum life should not be expected at the extreme limits of the temperature ranges.

Explanation of Pump Nomenclature, S1F Metallic - Design Level 1- Ball Valve

MODEL	Pump Series	Pump Size	Check Valve Type	Design Level	Wetted Material	Diaphragm/ Check Valve Materials	Check Valve Seat	Non-Wetted Material Options	Porting Options	Pump Style	Pump Options	Kit Options	Shipping Weight lbs. (kg)
S1FB1ABWANS000~	S	1F	B	1	A	B	W	A	N	S	0	00.	28 (13)
S1FB1AIWANS000~	S	1F	B	1	A	I	W	A	N	S	0	00.	28 (13)
S1FB1AGTANS000~	S	1F	B	1	A	G	T	A	N	S	0	00.	28 (13)
S1FB1A1WANS000~	S	1F	B	1	A	1	W	A	N	S	0	00.	28 (13)
S1FB1ACTANS000~	S	1F	B	1	A	C	T	A	N	S	0	00.	28 (13)
S1FB1IBWANS000~	S	1F	B	1	I	B	W	A	N	S	0	00.	46 (21)
S1FB1INWANS000~	S	1F	B	1	I	N	W	A	N	S	0	00.	46 (21)
S1FB1I1WANS000~	S	1F	B	1	I	1	W	A	N	S	0	00.	46 (21)
S1FB1ICTANS000~	S	1F	B	1	I	C	T	A	N	S	0	00.	46 (21)
S1FB1I1WANS000~	S	1F	B	1	I	I	W	A	N	S	0	00.	46 (21)
S1FB1SGTANS000~	S	1F	B	1	S	G	T	A	N	S	0	00.	43 (20)

Note: Models listed in the table are for reference only. See nomenclature below for other models.

Pump Series

S= Standard

Pump Size

1F=1"

Check Valve Type

B= Ball

Design Level

1= Design Level

Wetted Material

A= Aluminum

I= Cast Iron

S= Stainless Steel

H= Alloy C

Diaphragm Check Valve Materials

1= Santoprene/Santoprene

B= Nitrile/Nitrile

C= FKM/PTFE

I= EPDM/Santoprene

G= PTFE-Neoprene/PTFE

N= Neoprene/Neoprene

Z= One-Piece Bonded/PTFE

Check Valve Seat

A= Aluminum

C= Carbon Steel

S= Stainless Steel

T= PTFE

W= UHMW

Non-Wetted Material Options

A= Painted Aluminum

I= Cast Iron

Y= Painted Aluminum with Stainless Steel Hardware

Z= Cast Iron with Stainless Steel Hardware

Porting Options

N= NPT Threads

B= BSP (Tapered) Threads

R= Raised Face 150# Threaded ANSI Flange

Pump Style

S= Standard

Pump Options

0= None

1= Sound Dampening Muffler

2= Mesh Muffler

3= High temperature Air Valve w/Encapsulated Muffler

4= High temperature Air Valve w/Sound Dampening Muffler

5= High temperature Air Valve w/Mesh Muffler

▲6= Metal Muffler

▲7= Metal Muffler with Grounding Cable

Kit Options

▲00.= None

▲P0.= 10-30VDC Pulse Output Kit

◇P1.= Intrinsically-Safe 5-30VDC, 110/120VAC 220/240 VAC Pulse Output Kit

P2.= 110/120 or 220/240VAC Pulse Output Kit

E0.= Solenoid Kit with 24VDC Coil

▲E1.= Solenoid Kit with 24VDC Explosion-Proof Coil

E2.= Solenoid Kit with 24VAC/12VDC Coil

▲E3.= Solenoid Kit with 12VDC Explosion-Proof Coil

E4.= Solenoid Kit with 110VAC Coil

▲E5.= Solenoid Kit with 110VAC Explosion-Proof Coil

E6.= Solenoid Kit with 220VAC Coil

Kit Options continued

▲E7.= Solenoid Kit with 220VAC Explosion-Proof Coil

▲E8.= Solenoid Kit with 110VAC, 50 Hz Explosion-Proof Coil

▲E9.= Solenoid Kit with 230VAC, 50 Hz Explosion-Proof Coil

SP.= Stroke Indicator Pins

◆A1.= Solenoid Kit with 12 VDC ATEX Compliant Coil

◆A2.= Solenoid Kit with 24 VDC ATEX Compliant Coil

◆A3.= Solenoid Kit with 110/120 VAC 50/60 Hz ATEX Compliant Coil

◆A4.= Solenoid Kit with 220/240 VAC 50/60 Hz ATEX Compliant Coil

(1)  II 1G c T5
II 1D c T100°C
I M1 c
I M2 c

Models equipped with Wetted Options I, S or H, Non-Wetted Options I or Z Pump Options 6 or 7, and Kit Option 0.

Note: See page 31 for ATEX Explanation of EC-Type Certificate

II 2G c T5
II 2D c T100°C

Models equipped with Wetted Options A, I, S, or H, Non-Wetted Options A, I, Y, or Z, Pump Options 6 or 7, and Kit Option 0.

Note: See page 31 for ATEX Explanation of Type Examination Certificate

(2)  II 2G Ex ia c IIC T5
II 2D Ex c ia 20 IP67 T100°C

Note: Pumps ordered with the options listed in (1) to the left are ATEX compliant when ordered with kit option P1.

(3*)  II 2G EEx m c II T5
II 2D c IP65 T100°C

Note: Pumps ordered with the options listed in (1) to the left are ATEX compliant when ordered with kit option A1, A2, A3, or A4. Compressed Air Temperature Range: Maximum Ambient Temperature to plus 50°C.

*Note: See page 18 for Special Conditions For Safe Use.

(4)  IEC EEx m T4 

Note: Pump models equipped with these explosion-proof solenoid kit options E1, E3, E5, E7, E8 or E9, are certified and approved by the above agencies. They are NOT ATEX compliant.

Performance Curve, S1F Metallic Design Level 1

Performance based on the following: elastomer fitted pump, flooded suction, water at ambient conditions.
 The use of other materials and varying hydraulic conditions may result in deviations in excess of 5%.

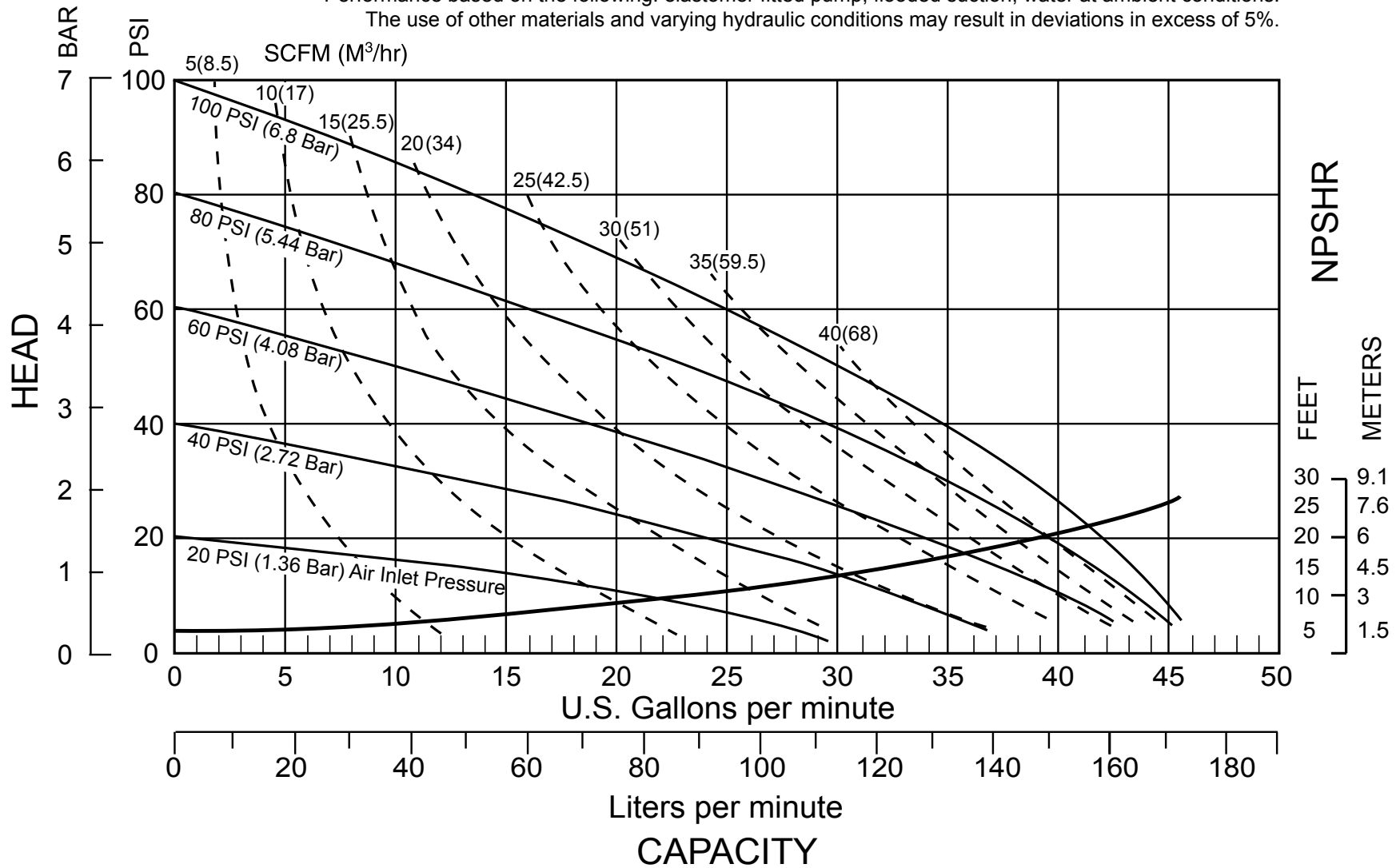

Dimensions: S1F Metallic

Dimensions in Inches

Dimensional Tolerance: $\pm 1/8"$

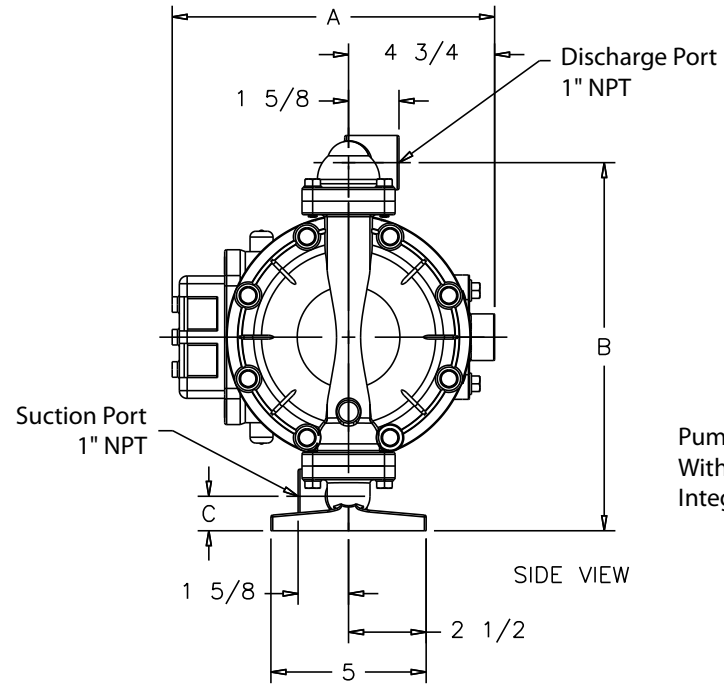
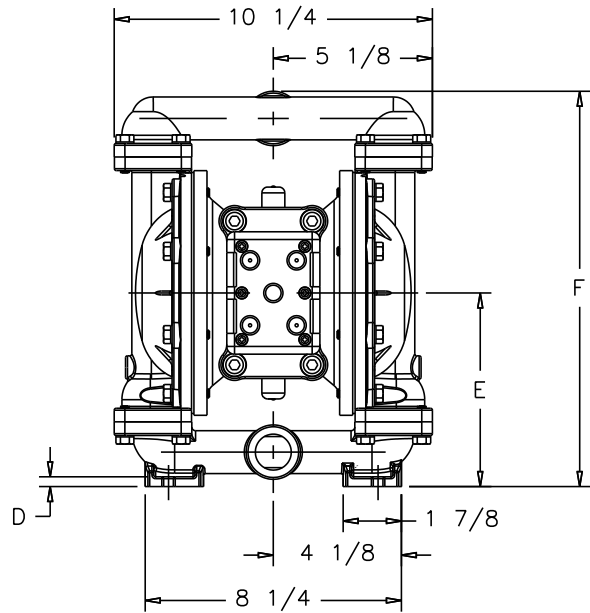

Pump Shown
With 530-028-550
Integral Muffler

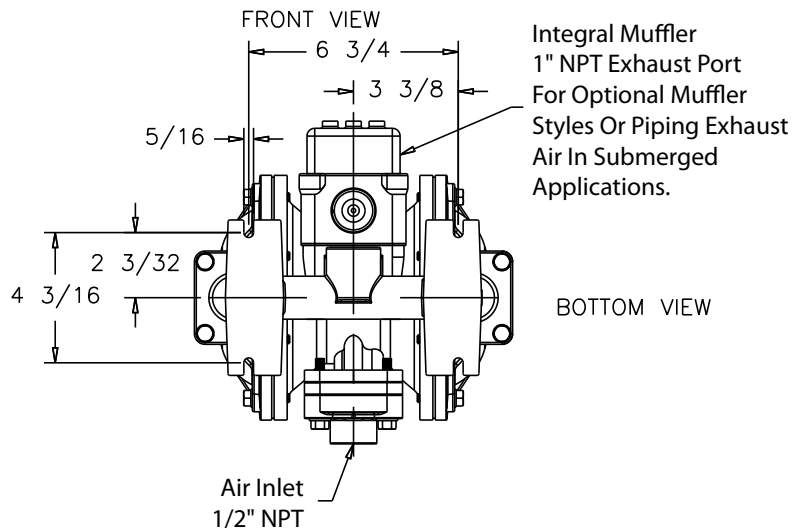

Dimension	A	B	C	D	E	F
Encapsulated Muffler	10 3/8					
Pulse Output Kit	10 3/8					
Aluminum		11 27/32	1 3/32	5/16	6 7/32	12 23/32
Stainless Steel		11 31/32	1 7/32	7/16	6 11/32	12 27/32
Mesh Muffler	13					
Sound Dampening Muffler	13					
Metal Muffler	12 1/2					

Metric Dimensions: S1F Metallic

Dimensions in Millimeters

Dimensional Tolerance: $\pm 3\text{mm}$

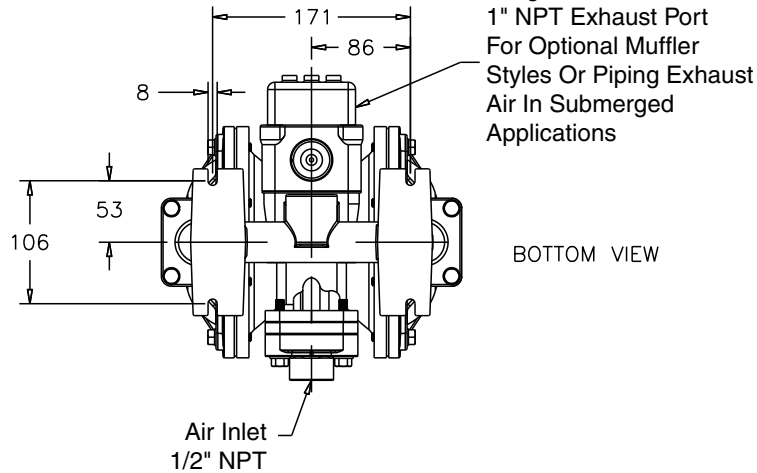
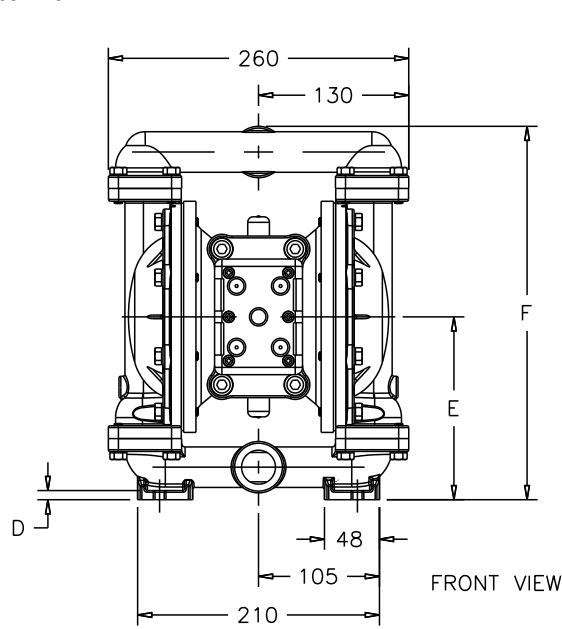

Integral Muffler
1" NPT Exhaust Port
For Optional Muffler
Styles Or Piping Exhaust
Air In Submerged
Applications

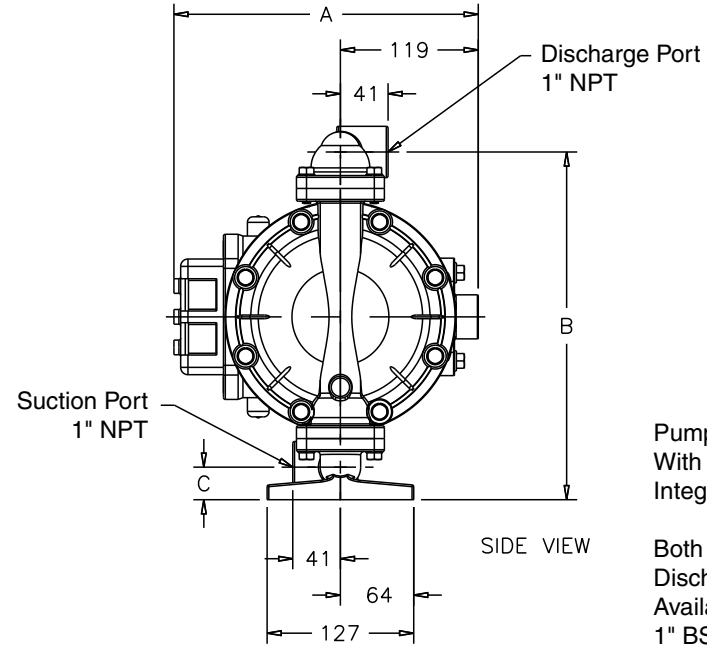

Pump Shown
With 530-028-550
Integral Muffler

Both Suction And
Discharge Ports Are
Available With
1" BSP Tapered Connection

Dimension	A	B	C	D	E	F
Encapsulated Muffler	264					
Pulse Output Kit	264					
Aluminum		301	28	8	158	323
Stainless Steel		304	31	11	161	326
Mesh Muffler	330					
Sound Dampening Muffler	330					
Metal Muffler	319					

PRINCIPLE OF PUMP OPERATION

This ball type check valve pump is powered by compressed air and is a 1:1 ratio design. The inner side of one diaphragm chamber is alternately pressurized while simultaneously exhausting the other inner chamber. This causes the diaphragms, which are connected by a common rod secured by plates to the centers of the diaphragms, to move in a reciprocating action. (As one diaphragm performs the discharge stroke the other diaphragm is pulled to perform the suction stroke in the opposite chamber.) Air pressure is applied over the entire inner surface of the diaphragm while liquid is discharged from the opposite side of the diaphragm. The diaphragm operates in a balanced condition during the discharge stroke which allows the pump to be operated at discharge heads over 200 feet (61 meters) of water.

For maximum diaphragm life, keep the pump as close to the liquid being pumped as possible. Positive suction head in excess of 10 feet of liquid (3.048 meters) may require a back pressure regulating device to maximize diaphragm life.

Alternate pressurizing and exhausting of the diaphragm chamber is performed by an externally mounted, pilot operated, four way spool type air distribution valve. When the spool shifts to one end of the valve body, inlet pressure is applied to one diaphragm chamber and the other diaphragm chamber exhausts. When the spool shifts to the opposite end of the valve body, the pressure to the chambers

is reversed. The air distribution valve spool is moved by a internal pilot valve which alternately pressurizes one end of the air distribution valve spool while exhausting the other end. The pilot valve is shifted at each end of the diaphragm stroke when a actuator plunger is contacted by the diaphragm plate. This actuator plunger then pushes the end of the pilot valve spool into position to activate the air distribution valve.

The chambers are connected with manifolds with a suction and discharge check valve for each chamber, maintaining flow in one direction through the pump.

INSTALLATION AND START-UP

Locate the pump as close to the product being pumped as possible. Keep the suction line length and number of fittings to a minimum. Do not reduce the suction line diameter.

For installations of rigid piping, short sections of flexible hose should be installed between the pump and the piping. The flexible hose reduces vibration and strain to the pumping system. A BRUIN Tranquilizer® surge suppressor is recommended to further reduce pulsation in flow.

AIR SUPPLY

Air supply pressure cannot exceed 125 psi (8.6 bar). Connect the pump air inlet to an air supply of sufficient capacity and pressure required for desired performance. When the air supply line is solid piping, use a short length of flexible hose not less than ½" (13mm) in diameter between the pump and the piping to reduce strain to the

piping. The weight of the air supply line, regulators and filters must be supported by some means other than the air inlet cap. Failure to provide support for the piping may result in damage to the pump. A pressure regulating valve should be installed to insure air supply pressure does not exceed recommended limits.

AIR VALVE LUBRICATION

The air distribution valve and the pilot valve are designed to operate WITHOUT lubrication. This is the preferred mode of operation. There may be instances of personal preference or poor quality air supplies when lubrication of the compressed air supply is required. The pump air system will operate with properly lubricated compressed air supply. Proper lubrication requires the use of an air line lubricator (available from BRUIN) set to deliver one drop of SAE 10 non-detergent oil for every 20 SCFM (9.4 liters/sec.) of air the pump consumes at the point of operation. Consult the pump's published Performance Curve to determine this.

AIR LINE MOISTURE

Water in the compressed air supply can create problems such as icing or freezing of the exhaust air, causing the pump to cycle erratically or stop operating. Water in the air supply can be reduced by using a point-of-use air dryer to supplement the user's air drying equipment. This device removes water from the compressed air supply and alleviates the icing or freezing problems.

AIR INLET AND PRIMING

To start the pump, open the air valve approximately ½ to ¾ turn. After the pump primes, the air valve can be opened to increase air flow as desired. If opening the valve increases cycling rate, but does not increase the rate of flow, cavitation has occurred. The valve should be closed slightly to obtain the most efficient air flow to pump flow ratio.

BETWEEN USES

When the pump is used for materials that tend to settle out or solidify when not in motion, the pump should be flushed after each use to prevent damage. (Product remaining in the pump between uses could dry out or settle out. This could cause problems with the diaphragms and check valves at restart.) In freezing temperatures the pump must be completely drained between uses in all cases.

TYPICAL INSTALLATION GUIDE

- ① TA1 or TA25 Tranquilizer
- ② 020-050-000 Filter/Regulator
- ③ 020-050-001 Lubricator
- ④ Air Dryer

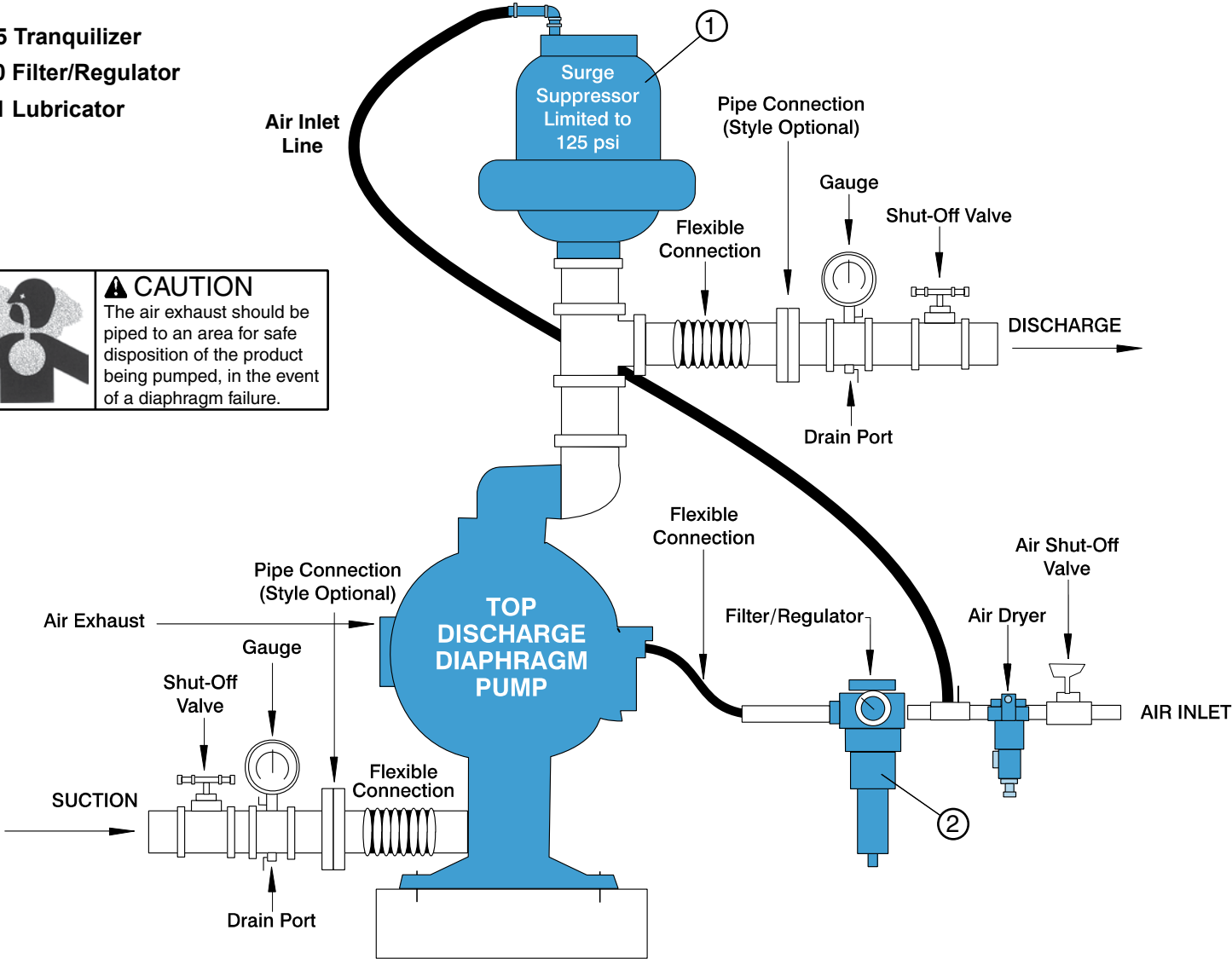
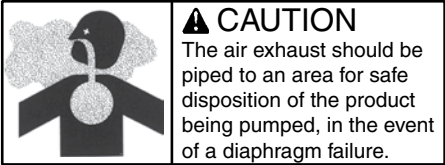

TROUBLESHOOTING

Possible Symptoms:

- Pump will not cycle.
- Pump cycles, but produces no flow.
- Pump cycles, but flow rate is unsatisfactory.
- Pump cycle seems unbalanced.
- Pump cycle seems to produce excessive vibration.

What to Check: Excessive suction lift in system.

Corrective Action: For lifts exceeding 20 feet (6 meters), filling the pumping chambers with liquid will prime the pump in most cases.

What to Check: Excessive flooded suction in system.

Corrective Action: For flooded conditions exceeding 10 feet (3 meters) of liquid, install a back pressure device.

What to Check: System head exceeds air supply pressure.

Corrective Action: Increase the inlet air pressure to the pump. Most diaphragm pumps are designed for 1:1 pressure ratio at zero flow.

What to Check: Air supply pressure or volume exceeds system head.

Corrective Action: Decrease inlet air pressure and volume to the pump as calculated on the published PERFORMANCE CURVE. Pump is cavitating the fluid by fast cycling.

What to Check: Undersized suction line.

Corrective Action: Meet or exceed pump connection recommendations shown on the DIMENSIONAL DRAWING.

What to Check: Restricted or undersized air line.

Corrective Action: Install a larger air line and connection. Refer to air inlet recommendations shown in your pump's SERVICE MANUAL.

What to Check: Check ESADS+Plus, the Externally Serviceable Air Distribution System of the pump.

Corrective Action: Disassemble and inspect the main air distribution valve, pilot valve and pilot valve actuators. Refer to the parts drawing and air valve section of the SERVICE MANUAL. Check for clogged discharge or closed valve before reassembly.

What to Check: Rigid pipe connections to pump.

Corrective Action: Install flexible connectors and a BRUIN Tranquilizer® surge suppressor.

What to Check: Blocked air exhaust muffler.

Corrective Action: Remove muffler screen, clean or de-ice and reinstall. Refer to the Air Exhaust section of your pump SERVICE MANUAL.

What to Check: Pumped fluid in air exhaust muffler.

Corrective Action: Disassemble pump chambers. Inspect for diaphragm rupture or loose diaphragm plate assembly. Refer to the Diaphragm Replacement section of your pump SERVICE MANUAL.

What to Check: Suction side air leakage or air in product.

Corrective Action: Visually inspect all suction side gaskets and pipe connections.

What to Check: Obstructed check valve.

Corrective Action: Disassemble the wet end of the pump and manually dislodge obstruction in the check valve pocket. Refer to the Check Valve section of the pump SERVICE MANUAL for disassembly instructions.

What to Check: Worn or misaligned check valve or check valve seat.

Corrective Action: Inspect check valves and seats for wear and proper seating. Replace if necessary. Refer to Check Valve section of the pump SERVICE MANUAL for disassembly instructions.

What to Check: Blocked suction line.

Corrective Action: Remove or flush obstruction. Check and clear all suction screens and strainers.

What to Check: Blocked discharge line.

Corrective Action: Check for obstruction or closed discharge line valves.

What to Check: Blocked pumping chamber.

Corrective Action: Disassemble and inspect the wetted chambers of the pump. Remove or flush any obstructions. Refer to the pump SERVICE MANUAL for disassembly instructions.

What to Check: Entrained air or vapor lock in one or both pumping chambers.

Corrective Action: Purge chambers through tapped chamber vent plugs. PURGING THE CHAMBERS OF AIR CAN BE DANGEROUS! Contact the BRUIN Technical Services Group before performing this procedure. Any model with top-ported discharge will reduce or eliminate problems with entrained air.

If your pump continues to perform below your expectations, contact your local BRUIN Distributor or factory Technical Services Group for a service evaluation.

WARRANTY

Refer to the enclosed BRUIN Warranty Certificate.

Recycling

Many components of BRUIN® Metallic AODD pumps are made of recyclable materials (see chart on page 10 for material specifications). We encourage pump users to recycle worn out parts and pumps whenever possible, after any hazardous pumped fluids are thoroughly flushed.

IMPORTANT SAFETY INFORMATION



IMPORTANT

Read these safety warnings and instructions in this manual completely, before installation and start-up of the pump. It is the responsibility of the purchaser to retain this manual for reference. Failure to comply with the recommendations stated in this manual will damage the pump, and void factory warranty.



CAUTION

Before pump operation, inspect all gasketed fasteners for looseness caused by gasket creep. Retorque loose fasteners to prevent leakage. Follow recommended torques stated in this manual.



WARNING

Before maintenance or repair, shut off the compressed air line, bleed the pressure, and disconnect the air line from the pump. The discharge line may be pressurized and must be bled of its pressure.



WARNING

In the event of diaphragm rupture, pumped material may enter the air end of the pump, and be discharged into the atmosphere. If pumping a product which is hazardous or toxic, the air exhaust must be piped to an appropriate area for safe disposition.



WARNING

Take action to prevent static sparking. Fire or explosion can result, especially when handling flammable liquids. The pump, piping, valves, containers or other miscellaneous equipment must be grounded. (See page 28)



WARNING

This pump is pressurized internally with air pressure during operation. Always make certain that all bolting is in good condition and that all of the correct bolting is reinstalled during assembly.



WARNING

When used for toxic or aggressive fluids, the pump should always be flushed clean prior to disassembly.



WARNING

Before doing any maintenance on the pump, be certain all pressure is completely vented from the pump, suction, discharge, piping, and all other openings and connections. Be certain the air supply is locked out or made non-operational, so that it cannot be started while work is being done on the pump. Be certain that approved eye protection and protective clothing are worn all times in the vicinity of the pump. Failure to follow these recommendations may result in serious injury or death.



WARNING

Airborne particles and loud noise hazards. Wear ear and eye protection.

MATERIAL CODES

THE LAST 3 DIGITS OF PART NUMBER

000	Assembly, sub-assembly; and some purchased items	306	Carbon Steel, Black PTFE Coated	374	Carboxylated Nitrile	607	Envelon
010	Cast Iron	307	Aluminum, Black Epoxy Coated	375	Fluorinated Nitrile	608	Conductive PTFE
012	Powered Metal	308	Stainless Steel, Black PTFE Coated	378	High Density Polypropylene	610	PTFE Encapsulated Silicon
015	Ductile Iron	309	Aluminum, Black PTFE Coated	379	Conductive Nitrile	611	PTFE Encapsulated FKM
020	Ferritic Malleable Iron	310	PVDF Coated	405	Cellulose Fibre	632	Neoprene/Hytrel
025	Music Wire	313	Aluminum, White Epoxy Coated	408	Cork and Neoprene	633	FKM/PTFE
080	Carbon Steel, AISI B-1112	330	Zinc Plated Steel	425	Compressed Fibre	634	EPDM/PTFE
100	Alloy 20	331	Chrome Plated Steel	426	Blue Gard	635	Neoprene/PTFE
110	Alloy Type 316 Stainless Steel	332	Aluminum, Electroless Nickel Plated	440	Vegetable Fibre	637	PTFE, FKM/PTFE
111	Alloy Type 316 Stainless Steel (Electro Polished)	333	Carbon Steel, Electroless Nickel Plated	465	Fibre	638	PTFE, Hytrel/PTFE
112	Alloy C	335	Galvanized Steel	500	Delrin 500	639	Nitrile/TFE
113	Alloy Type 316 Stainless Steel (Hand Polished)	336	Zinc Plated Yellow Brass	501	Delrin 570	643	Santoprene®/EPDM
114	303 Stainless Steel	337	Silver Plated Steel	502	Conductive Acetal, ESD-800	644	Santoprene®/PTFE
115	302/304 Stainless Steel	339	Nickel Plated	503	Conductive Acetal, Glass-Filled	656	Santoprene Diaphragm and Check Balls/EPDM Seats
117	440-C Stainless Steel (Martensitic)	340	Nickel Plated	505	Acrylic Resin Plastic	661	EPDM/Santoprene
120	416 Stainless Steel (Wrought Martensitic)	342	Filled Nylon	506	Delrin 150	666	FDA Nitrile Diaphragm, PTFE Overlay, Balls, and Seals
123	410 Stainless Steel (Wrought Martensitic)	351	Food Grade Santoprene	520	Injection Molded PVDF Natural color	668	PTFE, FDA Santoprene/PTFE
148	Hardcoat Anodized Aluminum	353	Geolast; Color: Black	540	Nylon		
149	2024-T4 Aluminum	354	Injection Molded #203-40 Santoprene- Duro 40D +/-5; Color: RED	541	Nylon		
150	6061-T6 Aluminum	355	Thermal Plastic	542	Nylon		
151	6063-T6 Aluminum	356	Hytrel	544	Nylon Injection Molded		Delrin and Hytrel are registered tradenames of E.I. DuPont.
152	2024-T4 Aluminum (2023-T351)	357	Injection Molded Polyurethane	550	Polyethylene		Gylon is a registered tradename of Garlock, Inc.
154	Almag 35 Aluminum	358	Urethane Rubber (Some Applications) (Compression Mold)	551	Glass Filled Polypropylene		Nylatron is a registered tradename of Polymer Corp.
155	356-T6 Aluminum	359	Urethane Rubber	552	Unfilled Polypropylene		Santoprene is a registered tradename of Exxon Mobil Corp.
156	356-T6 Aluminum	360	Nitrile Rubber Color coded: RED	553	Unfilled Polypropylene		
157	Die Cast Aluminum Alloy #380	361	Nitrile	555	Polyvinyl Chloride		
158	Aluminum Alloy SR-319	363	FKM (Fluorocarbon). Color coded: YELLOW	556	Black Vinyl		
159	Anodized Aluminum	364	E.P.D.M. Rubber. Color coded: BLUE	558	Conductive HDPE		
162	Brass, Yellow, Screw Machine Stock	365	Neoprene Rubber. Color coded: GREEN	570	Rulon II		Rulon II is a registered tradename of Dixon Industries Corp.
165	Cast Bronze, 85-5-5-5	366	Food Grade Nitrile	580	Ryton		Ryton is a registered tradename of Phillips Chemical Co.
166	Bronze, SAE 660	368	Food Grade EPDM	590	Valox		Valox is a registered tradename of General Electric Co.
170	Bronze, Bearing Type, Oil Impregnated	370	Butyl Rubber Color coded: BROWN	591	Nylatron G-S		
175	Die Cast Zinc	371	Phlthane (Tuftane)	592	Nylatron NSB		
180	Copper Alloy			600	PTFE (virgin material) Tetrafluorocarbon (TFE)		
305	Carbon Steel, Black Epoxy Coated			601	PTFE (Bronze and moly filled)		
				602	Filled PTFE		
				603	Blue Gylon		
				604	PTFE		
				606	PTFE		

Composite Repair Parts Drawing

AVAILABLE SERVICE AND CONVERSION KITS

- 476-319-000 AIR END KIT (Aluminum Center)**
Seals, O-ring, Gaskets, Retaining Rings, Plungers, & Bushings
- 476-201-000 AIR END KIT (Air Valve with Stroke Indicator Pin, Aluminum Center)**
Seals, O-ring, Gaskets, Retaining Rings, Air Valve Sleeve and Spool Set, and Pilot Valve Assembly.
- 476-194-354 ~ WET END KIT**
Santoprene Diaphragms, Balls and PTFE Seats, U-Cup Seal.
- 476-194-360 ~ WET END KIT**
Nitrile Diaphragms, Balls, and UHMW Seats, U-Cup Seal.
- 476-194-365 WET END KIT**
Neoprene Diaphragms, Balls, and UHMW Seats.
- 476-194-633 ~ WET END KIT**
FKM Diaphragms, PTFE Overlay, PTFE Balls and Seats, U-Cup Seal.
- 476-194-635 WET END KIT**
Neoprene Diaphragms, PTFE Overlay Balls and Seats.
- 476-194-654 WET END KIT**
Santoprene Diaphragms, PTFE Overlay, PTFE Balls, PTFE Seats.
- 476-194-661 WET END KIT**
EPDM Diaphragms, Santoprene Balls and Polyethylene Seats.
- 476-194-659 WETTED END KIT**
One-Piece Bonded PTFE/Nitrile Diaphragm, PTFE Balls, PTFE Seats.

HARDWARE KITS

- 475-212-330** Zinc Plated Capscrews, Washers, and Hex Nuts.
- 475-212-115** Stainless Steel Capscrews, Washers, and Hex Nuts.

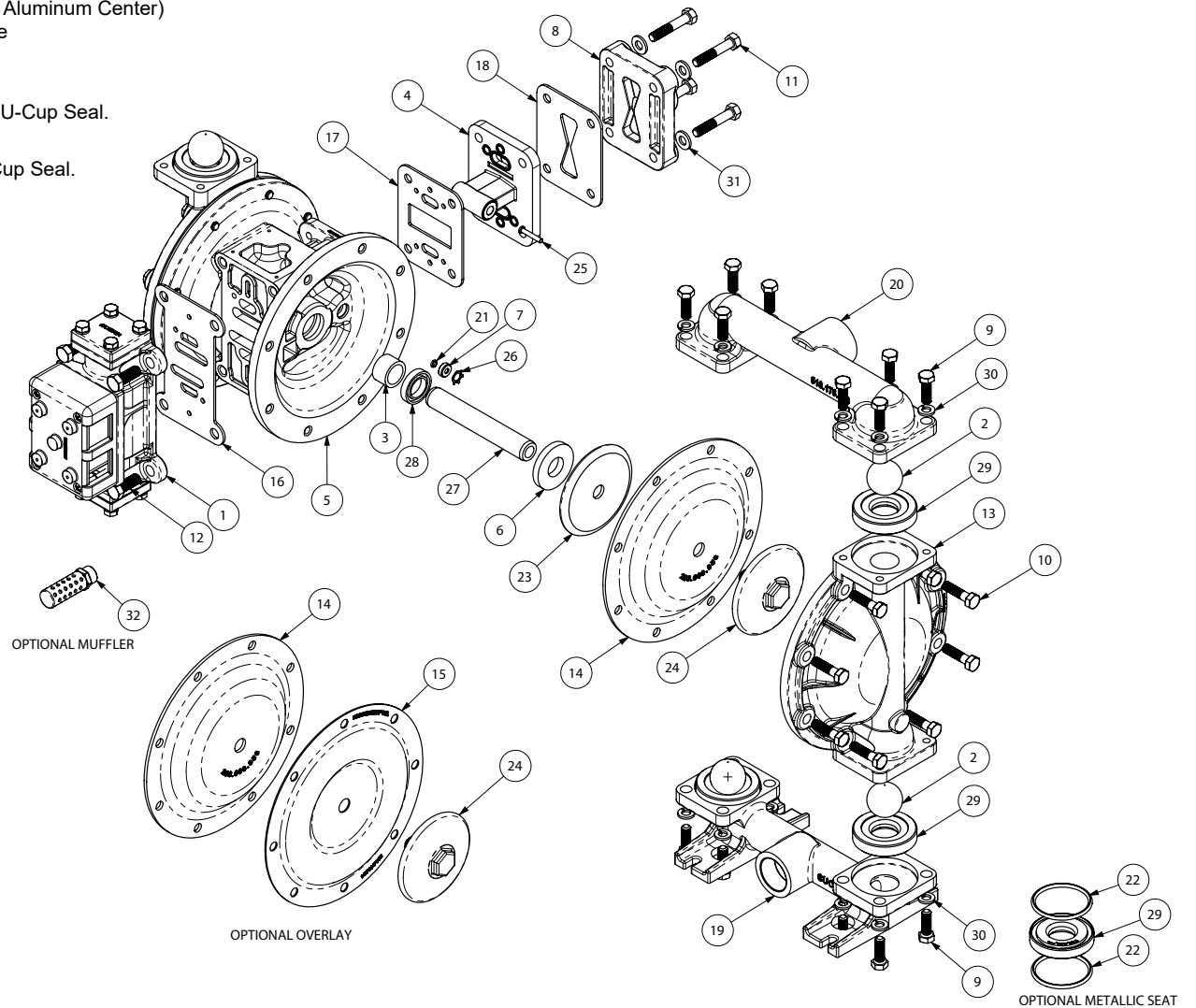

Composite Repair Parts List

ITEM	PART NUMBER	DESCRIPTION	QTY	ITEM	PART NUMBER	DESCRIPTION	QTY
1	▲ 031-179-000	Air Valve Assembly (Cast Iron Centers Only)	1		518-175-156E	Manifold, Suction 1" BSP Tapered	1
	▲ 031-146-000	Air Valve Assembly (Stroke Indicator)	1		518-175-010	Manifold, Suction	1
	▲ 031-147-000	Air Valve Assembly (Stroke Indicator)	1		518-175-010E	Manifold, Suction 1" BSP Tapered	1
	▲ 031-183-000	Air Valve Assembly	1		518-175-110	Manifold, Suction	1
	▲ 031-183-001	Air Valve Assembly (W/Stainless Steel Hardware)	1		518-175-110E	Manifold, Suction 1" BSP Tapered	1
	031-173-000	Air Valve Assembly (W/ Aluminum centers only)	1	20	518-176-156	Manifold, Discharge	1
	031-173-001	Air Valve Assembly (W/ Stainless Steel Hardware only)	1		518-176-156E	Manifold, Discharge 1" BSP Tapered	1
					518-176-010	Manifold, Discharge	1
					518-176-010E	Manifold, Discharge 1" BSP Tapered	1
					518-176-110	Manifold, Discharge	1
2	050-028-354	Ball, Check	4		518-176-110E	Manifold, Discharge 1" BSP Tapered	1
	050-028-360	Ball, Check	4	21	560-001-360	O-Ring	2
	050-028-365	Ball, Check	4	22	560-091-360	Seal (Check Valve) (See item 29)	8
	050-028-600	Ball, Check	4		560-091-363	Seal (Check Valve) (See item 29)	8
3	070-012-170	Bushing	2		560-091-364	Seal (Check Valve) (See item 29)	8
4	095-110-000	Pilot Valve Assembly	1		560-091-365	Seal (Check Valve) (See item 29)	8
	095-110-558	Pilot Valve Assembly (Cast Iron Centers Only)	1		560-091-611	Seal (Check Valve) (See item 29)	8
				23	612-022-330	Plate, Inner Diaphragm	2
5	114-025-157	Intermediate	1		612-218-330	Plate, Inner Diaphragm	2
	114-025-010	Intermediate	1			(use with One-Piece Bonded)	
6	132-019-360	Bumper	2	24	612-108-157	Plate, Outer Diaphragm Assembly	2
7	135-036-506	Bushing	2		612-101-082	Plate, Outer Diaphragm Assembly	2
8	165-120-157	Cap, Air Inlet Assembly	1		612-101-110	Plate, Outer Diaphragm Assembly	2
	165-120-010	Cap, Air Inlet Assembly	1	25	620-022-115	Pin, Actuator	2
9	170-044-115	Capscrew, Hex Hd 5/16-18 X 1.00	16	26	675-042-115	Ring, Retaining	2
	170-044-330	Capscrew, Hex Hd 5/16-18 X 1.00	16	27	685-060-120	Rod, Diaphragm	1
10	170-045-115	Capscrew, Hex Hd 5/16-18 X 1.25	16	28	720-010-375	Seal, U-Cup	2
	170-045-330	Capscrew, Hex Hd 5/16-18 X 1.25	16	29	722-098-550	Seat, Check Ball	4
11	170-069-115	Capscrew, Hex Hd 5/16-18 X 1.75	4		722-098-080	Seat, Check Ball (seals required see item 22)	4
	170-069-330	Capscrew, Hex Hd 5/16-18 X 1.75	4		722-098-110	Seat, Check Ball (seals required see item 22)	4
12	171-053-115	Capscrew, Hex Soc 3/8-16 X 2.50	4		722-098-150	Seat, Check Ball (seals required see item 22)	4
		(Stroke Indicator option only)			722-098-600	Seat, Check Ball	4
	171-053-330	Capscrew, Hex Soc 3/8-16 X 2.50	4	30	900-004-330	Lock Washer, 5/16	16
		(Stroke Indicator option only)			900-004-115	Lock Washer, 5/16	16
	170-006-115	Capscrew, Hex HD 3/8-16 X 1.00	4	31	901-038-330	Flat Washer, 5/16	4
	170-006-330	Capscrew, Hex HD 3/8-16 X 1.00	4		901-038-115	Flat Washer, 5/16	4
13	196-173-156/157	Chamber, Outer	2	▲ 32	530-033-000	Muffler, Metal	1
	196-173-010	Chamber, Outer	2				
	196-173-110	Chamber, Outer	2				
14	286-008-354	Diaphragm	2				
	286-008-360	Diaphragm	2				
	286-008-363	Diaphragm	2				
	286-008-364	Diaphragm	2				
	286-008-365	Diaphragm	2				
	286-112-000	Diaphragm, One-Piece Bonded	2				
15	286-015-604	Diaphragm, Overlay	2				
16	360-093-360	Gasket, Air Valve	1				
17	360-103-360	Gasket, Pilot Valve	1				
18	360-104-379	Gasket, Air Inlet Cap	1				
19	518-175-156	Manifold, Suction	1				

Parts not shown used with Raised Face Flange Porting Option

170-044-330	Hex Cap Screw	4
326-050-080	Mounting Bracket	2
334-112-110	1" Raised Face, 150# ANSI Flange	2
538-035-110	Pipe Nipple 1" NPT x 1½"	2
545-004-330	Hex Nut	4
900-004-330	Lock Washer	4
901-009-330	Flat Washer	8



Air Valve Servicing, Assembly Drawing & Parts List (Use With Aluminum Centers Only)

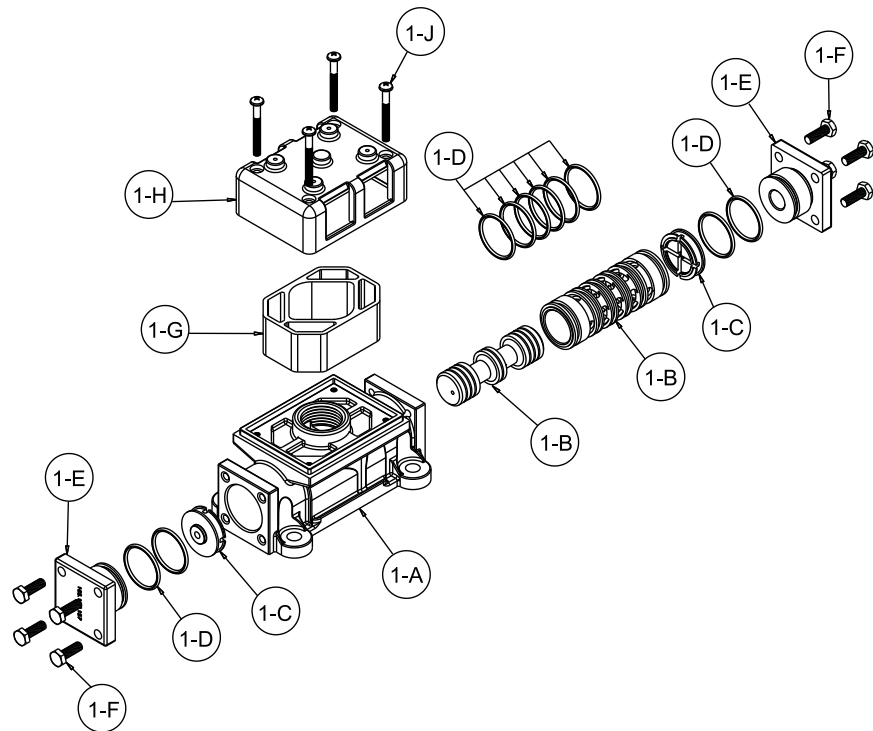

**AIR VALVE ASSEMBLY PARTS LIST

Item	Part Number	Description	Qty
1	031-173-000	Air Valve Assembly	1
1-A	095-109-157	Body, Air Valve	1
1-B	031-139-000	Sleeve and Spool Set	1
1-C	132-029-552	Bumper	2
1-D	560-020-360	O-Ring	10
1-E	165-127-157	Cap, End	2
1-F	170-032-330	Hex Head Capscrew 1/4-20 x .75	8
1-G	530-028-550	Muffler	1
1-H	165-096-551	Muffler Cap	1
1-J	706-026-330	Machine Screw	4

**AIR VALVE ASSEMBLY PARTS LIST

1	031-173-001	Air Valve Assembly	1
Consists of all components above except:			
1-F	170-032-115	Hex Head Capscrew 1/4-20 x .75	8
1-J	706-026-115	Machine Screw	4

****Note: Pumps equipped with these Valve Assemblies are not ATEX compliant.**

AIR DISTRIBUTION VALVE SERVICING

To service the air valve first shut off the compressed air, bleed pressure from the pump, and disconnect the air supply line from the pump.

Step #1: See COMPOSITE REPAIR PARTS DRAWING.

Using a 9/16" wrench or socket, remove the four hex capscrews (items 12). Remove the air valve assembly from the pump.

Remove and inspect gasket (item 16) for cracks or damage. Replace gasket if needed.

Step #2: Disassembly of the air valve.

Using a 7/16" wrench or socket, remove the eight hex capscrews (items 1-F) that

fasten the end caps to the valve body. Next remove the two end caps (items 1-E). Inspect the two o-rings (items 1-D) on each end cap for damage or wear. Replace the o-rings as needed.

Remove the bumpers (items 1-C). Inspect the bumpers for damage or wear. Replace the bumpers as needed.

Remove the spool (part of item 1-B) from the sleeve. Be careful not to scratch or damage the outer diameter of the spool. Wipe spool with a soft cloth and inspect for scratches or wear.

Inspect the inner diameter of the sleeve (part of item 1-B) for dirt, scratches, or other contaminants. Remove the sleeve if needed and replace with a new sleeve and spool set (item 1-B).

Step #3: Reassembly of the air valve.

Install one bumper (item 1-C) and one end cap (item 1-E), with two o-rings (items 1-D), and fasten with four hex capscrews (items 1-F) to the valve body (item 1-A).

Remove the new sleeve and spool set (item 1-B) from the plastic bag. Carefully remove the spool from the sleeve. Install the six o-rings (item 1-D) into the six grooves on the sleeve. Apply a light coating of grease to the o-rings before installing the sleeve into the valve body (item 1-A), align the slots in the sleeve with the slots in the valve body. Insert the spool into the sleeve. Be careful not to scratch or damage the spool during installation. Carefully insert the sleeve into the bumper and end cap

(with o-rings) and fasten with the remaining hex capscrews.

Fasten the air valve assembly (item 1) and gasket to the pump. Connect the compressed air line to the pump. The pump is now ready for operation.



! IMPORTANT

Read these instructions completely, before installation and start-up. It is the responsibility of the purchaser to retain this manual for reference. Failure to comply with the recommendations stated in this manual will damage the pump, and void factory warranty.

Air Valve Servicing, Assembly Drawing & Parts List

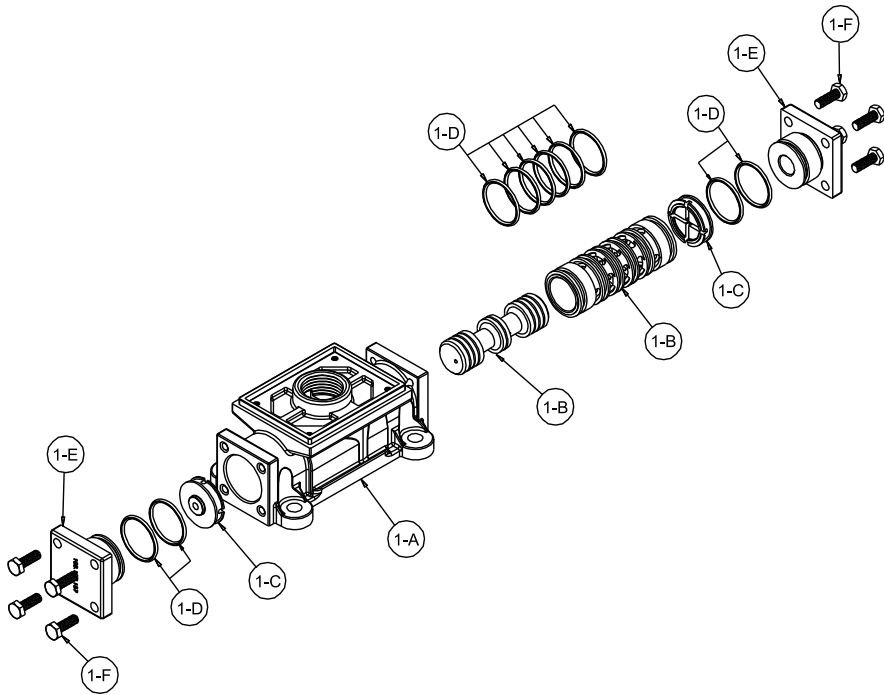

AIR VALVE ASSEMBLY PARTS LIST (Use w/Aluminum center sections)

Item	Part Number	Description	Qty
⚠ 1	031-183-000	Air Valve Assembly	1
1-A	095-109-157	Body, Air Valve	1
1-B	031-139-000	Sleeve and Spool Set	1
1-C	132-029-552	Bumper	2
1-D	560-020-360	O-Ring	10
1-E	165-127-157	Cap, End	2
1-F	170-032-330	Hex Head Capscrew 1/4-20 x .75	8

AIR VALVE ASSEMBLY PARTS LIST

⚠ 1	031-183-001	Air Valve Assembly	1
Consists of all components above except:			
1-F	170-032-115	Hex Head Capscrew 1/4-20 x .75	8



AIR DISTRIBUTION VALVE SERVICING

To service the air valve first shut off the compressed air, bleed pressure from the pump, and disconnect the air supply line from the pump.

Step #1: See COMPOSITE REPAIR PARTS DRAWING.

Using a 9/16" wrench or socket, remove the four hex capscrews (items 12). Remove the air valve assembly from the pump.

Remove and inspect gasket (item 16) for cracks or damage. Replace gasket if needed.

Step #2: Disassembly of the air valve.

Using a 7/16" wrench or socket, remove the eight hex capscrews (items 1-F) that

fasten the end caps to the valve body. Next remove the two end caps (items 1-E). Inspect the two o-rings (items 1-D) on each end cap for damage or wear. Replace the o-rings as needed.

Remove the bumpers (items 1-C). Inspect the bumpers for damage or wear. Replace the bumpers as needed.

Remove the spool (part of item 1-B) from the sleeve. Be careful not to scratch or damage the outer diameter of the spool. Wipe spool with a soft cloth and inspect for scratches or wear.

Inspect the inner diameter of the sleeve (part of item 1-B) for dirt, scratches, or other contaminants. Remove the sleeve if needed and replace with a new sleeve and spool set (item 1-B).

Step #3: Reassembly of the air valve.

Install one bumper (item 1-C) and one end cap (item 1-E), with two o-rings (items 1-D), and fasten with four hex capscrews (items 1-F) to the valve body (item 1-A).

Remove the new sleeve and spool set (item 1-B) from the plastic bag. Carefully remove the spool from the sleeve. Install the six o-rings (item 1-D) into the six grooves on the sleeve. Apply a light coating of grease to the o-rings before installing the sleeve into the valve body (item 1-A), align the slots in the sleeve with the slots in the valve body. Insert the spool into the sleeve. Be careful not to scratch or damage the spool during installation. Carefully insert the sleeve into the bumper and end cap (with o-rings) and fasten with the remaining hex capscrews.

Fasten the air valve assembly (item 1) and gasket to the pump. Connect the compressed air line to the pump. The pump is now ready for operation.



⚠ IMPORTANT

Read these instructions completely, before installation and start-up. It is the responsibility of the purchaser to retain

this manual for reference. Failure to comply with the recommendations stated in this manual will damage the pump, and void factory warranty.

Air Valve Assembly Drawing, Parts List (Use With Cast Iron Centers Only)

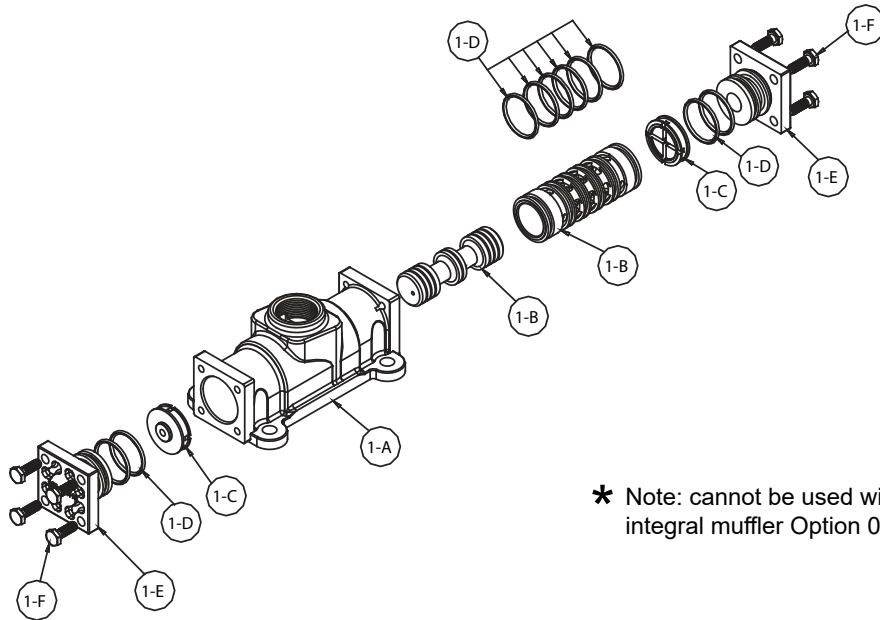

Air Valve Assembly Parts List

Item	Part Number	Description	Qty
▲ 1	031-179-000 *	Gas Valve Assembly	1
1-A	095-109-110	Valve Body	1
1-B	031-139-000	Sleeve and Spool Set	1
1-C	132-029-552	Bumper	2
1-D	560-020-360	O-Ring	10
1-E	165-127-110	Cap, End	2
1-F	170-032-115	Capscrew	8

* Note: cannot be used with integral muffler Option 0.



AIR DISTRIBUTION VALVE WITH STROKE INDICATOR OPTION SERVICING

To service the air valve first shut off the compressed air supply, bleed the pressure from the pump, and disconnect the air supply line from the pump.

Step #1: See COMPOSITE REPAIR PARTS DRAWING.

Using a 5/16" Allen wrench, remove the four hex socket capscrews (item 12) and four flat washers (item 39). Remove the air valve assembly from the pump.

Remove and inspect gasket (item 19) for cracks or damage. Replace gasket if needed.

Step #2: Disassembly of the air valve.

To access the internal air valve components first remove the two retaining rings (item 1-H) from each end of the air valve assembly using clip ring pliers.

Next remove the two end caps (item 1-E). Inspect the o-ring (items 1-G) for cuts or wear. Replace the o-rings if necessary.

Remove the spool (part of item 1-A) from the sleeve. Be careful not to scratch or damage the outer diameter of the spool. Wipe spool with a soft cloth and inspect for scratches or wear.

Inspect the inner diameter of the sleeve (part of item 1-A) for dirt, scratches, or other contaminants. Remove the sleeve if needed and replace with a new sleeve and spool set (item 1-A).

Step #3: Reassembly of the air valve.

Install one end cap (item 1-E) with o-ring (item 1-G) into one end of the air valve body (item 1-B). Install one retaining ring (item 1-H), into the groove on the same end.

Remove the new sleeve and spool set (item 1-A) from the plastic bag. Carefully remove the spool from the sleeve. Install the six o-rings (item 1-G) into the six grooves on the sleeve. Apply a light coating of grease to the o-rings before installing the sleeve into the valve body (item 1-B). Align the slots in the sleeve with the slots in the valve body. Insert the spool into the sleeve. Be careful not to scratch or damage the spool during installation. Push the spool in until it touches the bumper on the opposite end.

Install the remaining end cap with

o-rings and retaining ring.

Fasten the air valve assembly (item 1) and gasket (item 19) to the pump.

Connect the compressed air line to the pump. Remove the safety clip. The pump is now ready for operation.



▲ IMPORTANT

Read these instructions completely, before installation and start-up. It is the responsibility of the purchaser to retain this manual for reference. Failure to comply with the recommendations stated in this manual will damage the pump, and void factory warranty.

Air Valve with Stroke Indicator Assembly Drawing, Parts List

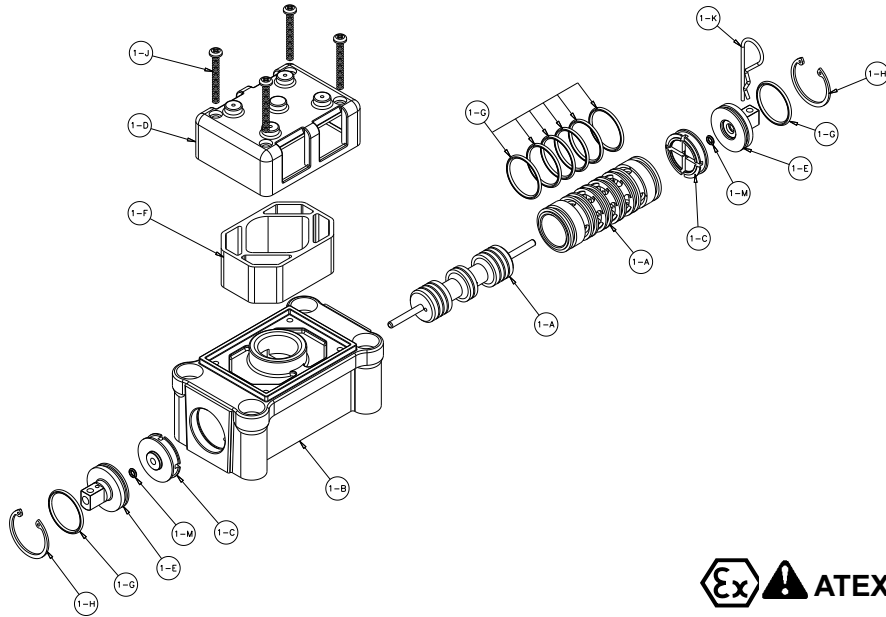

 **ATEX Compliant**

AIR VALVE ASSEMBLY PARTS LIST

Item	Part Number	Description	Qty
 1	031-146-000	Air Valve Assembly	1
1-A	031-143-000	Sleeve and Spool Set	1
1-B	095-094-559	Body, Air Valve	1
1-C	132-029-552	Bumper	2
1-D	165-096-559	Cap, Muffler	1
1-E	165-098-147	Cap, End	2
1-F	530-028-550	Muffler	1
1-G	560-020-360	O-Ring	8
1-H	675-044-115	Ring, Retaining	2
1-J	710-015-115	Screw, Self Tapping	4
1-K	210-008-330	Clip, Safety	1
1-M	560-029-360	O-Ring	2

For Pumps with Alternate Mesh, Sound Dampening Mufflers or Piped Exhaust:

 1	031-147-000	Air Valve Assembly	1
---	-------------	--------------------	---

(includes all items on 031-146-000 minus 1-D, 1-F, & 1-J).

AIR DISTRIBUTION VALVE WITH STROKEINDICATOROPTIONSERVICING

To service the air valve first shut off the compressed air supply, bleed the pressure from the pump, and disconnect the air supply line from the pump.

Step #1: See COMPOSITE REPAIR PARTS DRAWING.

Using a 5/16" Allen wrench, remove the four hex socket capscrews (item 12) and four flat washers (item 39). Remove the air valve assembly from the pump.

Remove and inspect gasket (item 19) for cracks or damage. Replace gasket if needed.

Step #2: Disassembly of the air valve.

To access the internal air valve components first remove the two retaining

rings (item 1-H) from each end of the air valve assembly using clip ring pliers.

Next remove the two end caps (item 1-E). Inspect the o-ring (items 1-G) and 1-M) for cuts or wear. Replace the o-rings if necessary.

Remove the two bumpers (item 1-C). Inspect the bumpers for cut, wear or abrasion. Replace if necessary.

Remove the spool (part of item 1-A) from the sleeve. Be careful not to scratch or damage the outer diameter of the spool. Wipe spool with a soft cloth and inspect for scratches or wear.

Inspect the inner diameter of the sleeve (part of item 1-A) for dirt, scratches, or other contaminants. Remove the sleeve if needed and replace with a new sleeve and spool set (item 1-A).

Step #3: Reassembly of the air valve.

Install one bumper (item 1-C) and one end cap (item 1-E) with o-rings (item 1-G and 1-M) into one end of the air valve body (item 1-B). Install one retaining ring (item 1-H), into the groove on the same end. Insert the safety clip (item 1-K) through the smaller unthreaded hole in the endcap.

Remove the new sleeve and spool set (item 1-A) from the plastic bag. Carefully remove the spool from the sleeve. Install the six o-rings (item 1-G) into the six grooves on the sleeve. Apply a light coating of grease to the o-rings before installing the sleeve into the valve body (item 1-B). Align the slots in the sleeve with the slots in the valve body. Insert the spool into the sleeve. Be careful not to scratch or damage the spool during installation. Push the spool in until the pin touches the safety clip on the opposite end.

Install the remaining bumper, end cap with o-rings and retaining ring.

Fasten the air valve assembly (item 1) and gasket (item 19) to the pump.

Connect the compressed air line to the pump. Remove the safety clip. The pump is now ready for operation.



IMPORTANT

Read these instructions completely, before installation and start-up. It is the responsibility of the purchaser to retain

this manual for reference. Failure to comply with the recommendations stated in this manual will damage the pump, and void factory warranty.

Solenoid Shifted Air Valve Drawing

SOLENOID SHIFTED AIR VALVE PARTS LIST

(Includes all items used on Composite Repair Parts List except as shown)

ITEM	PART NUMBER	DESCRIPTION	QTY
33	893-097-000	Solenoid Valve, NEMA4	1
34	219-001-000	Solenoid Coil, 24VDC	1
	219-004-000	Solenoid Coil, 24VAC/12VDC	1
	219-002-000	Solenoid Coil, 120VAC	1
	219-003-000	Solenoid Coil, 240VAC	1
	241-001-000	Connector, conduit	1
35	241-003-000	Conduit Connector with Suppression Diode (DC Only)	1
	170-045-330	Capscrew, Hex HD 5/16-18 x 1.25	4
36	618-050-150	Plug	2
37			



IEC EEX m T4



▲ For Explosion Proof Solenoid Coils used in North America and outside the European Union.

34	219-009-001	Solenoid Coil, 120VAC 60 Hz	1
	219-009-002	Solenoid Coil, 240VAC 60 Hz	1
	219-009-003	Solenoid Coil, 12VDC	1
	219-009-004	Solenoid Coil, 24VDC	1
	219-009-005	Solenoid Coil, 110VAC 50 Hz	1
	219-009-006	Solenoid Coil, 230VAC 50 Hz	1

Note: Item 35 (Conduit Connector) is not required



II 2G EEx M c II T5
II 3/2 G EX M c II T5
II 2D c IP65 T100°C

*◆ For ATEX Compliant Solenoid Coils used in the European Union

34	219-011-001	Solenoid Coil, Single mounting 12 VDC, 3.3W / 267mA	1
	219-011-002	Solenoid Coil, Single mounting 24 VDC, 3.3W / 136mA	1
	219-011-003	Solenoid Coil, Single mounting 110/120 VAC, 3.4W / 29mA	1
	219-011-004	Solenoid Coil, Single mounting 220/240 VAC, 3.4W / 15mA	1

Note: Item 35 (Conduit Connector) is not required

Compressed Air Temperature Range: Maximum Ambient Temperature to plus 50°C

*Special Conditions For Safe Use

A fuse corresponding to its rated current (max. $3 \cdot I_{rat}$ according IEC 60127-2-1) or a motor protecting switch with short-circuit and thermal instantaneous tripping (set to rated current) shall be connected in series to each solenoid as short circuit protection. For very low rated currents of the solenoid the fuse of lowest current value according to the indicated IEC standard will be sufficient. The fuse may be accommodated in the associated supply unit or shall be separately arranged. The rated voltage to the fuse shall be equal to or greater than the stated rated voltage of the magnet coil. The breakage capacity of the fuse-link shall be as high as or higher than the maximum expected short circuit current at the location of the installation (usually 1500 A). A maximum permissible ripple of 20% is valid for all magnets of direct-current design.

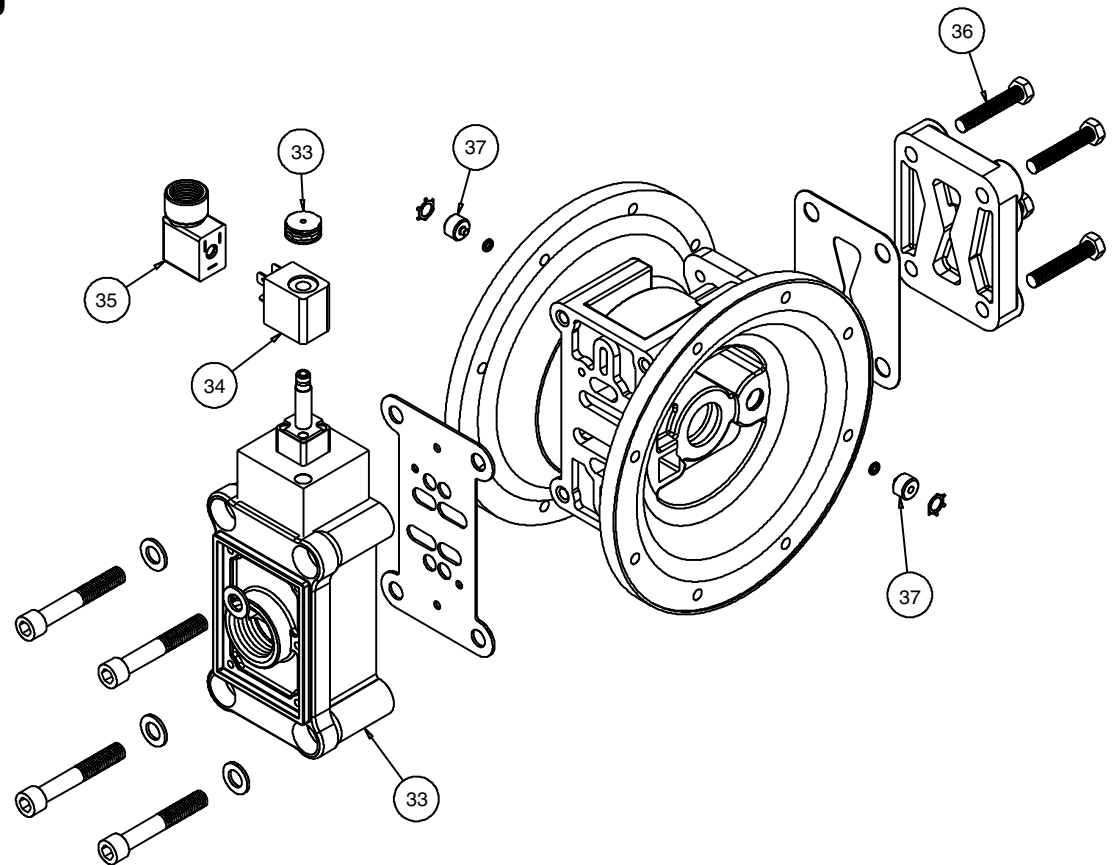

SOLENOID SHIFTED AIR DISTRIBUTION VALVE OPTION

BRUIN's solenoid shifted, air distribution valve option utilizes electrical signals to precisely control your BRUINs speed. The solenoid coil is connected to a customer - supplied control. Compressed air provides the pumping power, while electrical signals control pump speed (pumping rate).

OPERATION

The Solenoid Shifted BRUIN has a solenoid operated, air distribution valve in place of the standard BRUINs pilot operated, air distribution valve. Where a pilot valve is normally utilized to cycle the pump's air distribution valve, an electric solenoid is utilized. As the solenoid is powered, one of the pump's air chambers is pressurized while the other chamber is exhausted. When electric power is turned off, the solenoid shifts and the pressurized chamber is exhausted while the other chamber is pressurized. By alternately applying and removing power to the solenoid, the pump cycles much like a standard BRUIN pump, with one exception. This option provides a way to precisely control and monitor pump speed.

BEFORE INSTALLATION

Before wiring the solenoid, make certain it is compatible with your system voltage.

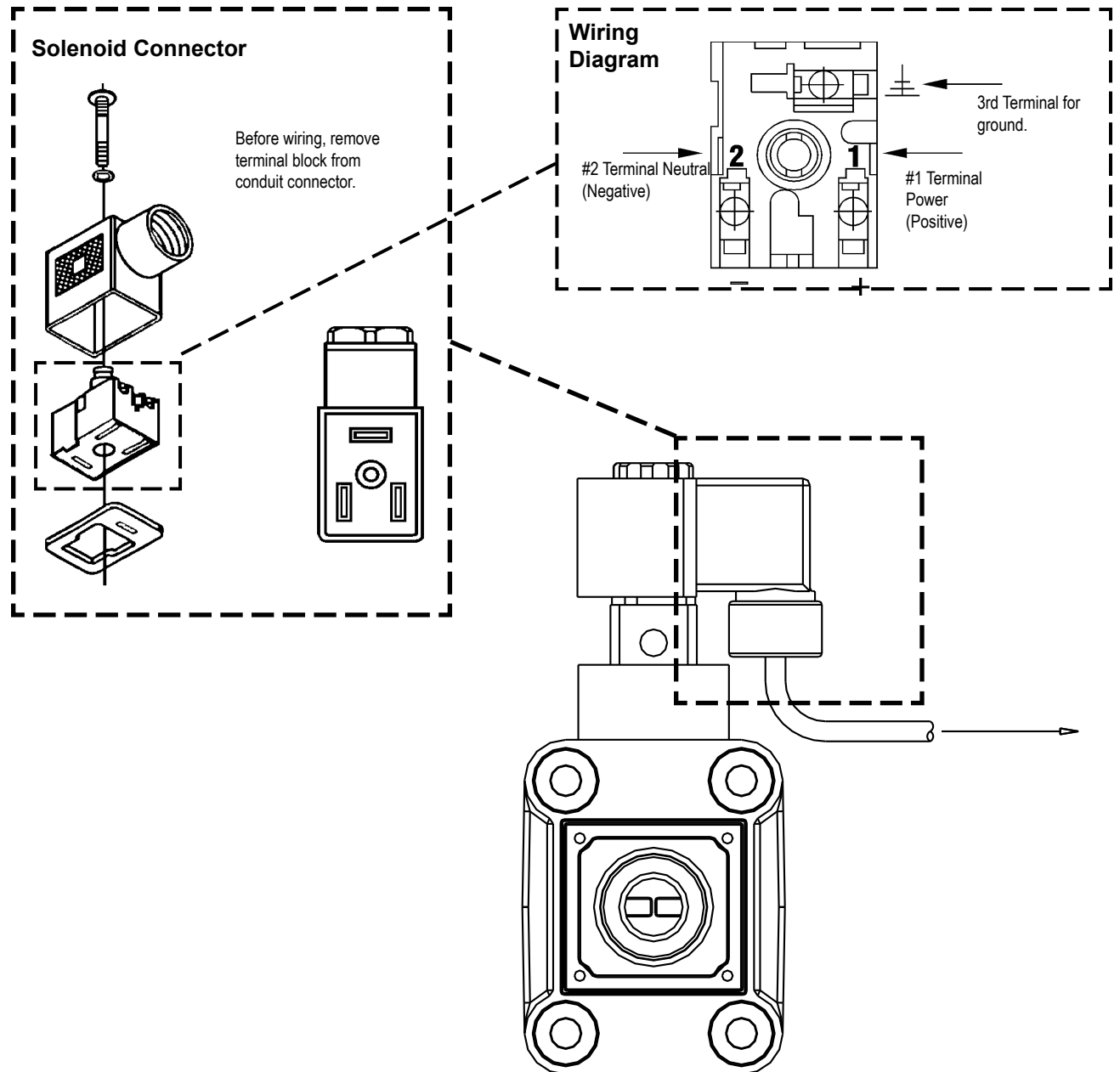

Diaphragm Service Drawing, with Overlay

Diaphragm Service Drawing, Non-Overlay

One-Piece Bonded * Diaphragm Service Drawing

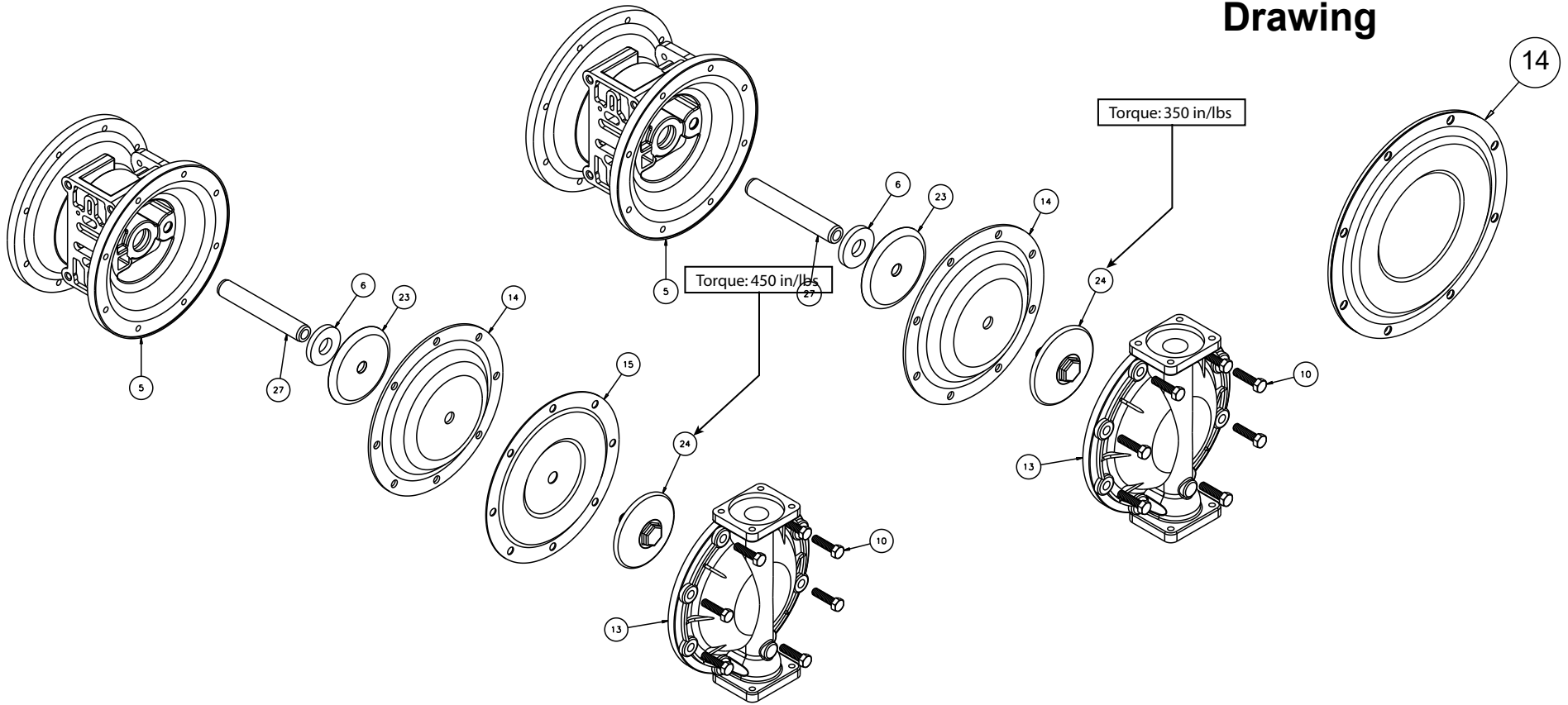

***AVAILABLE FOR FIELD CONVERSION FROM OVERLAY
TO ONE-PIECE BONDED DIAPHRAGM KITS:**

Kit: 475-250-000
 2 286-112-000 One-Piece Diaphragm
 2 612-218-330 Inner Plates

DIAPHRAGM SERVICING

To service the diaphragms first shut off the suction, then shut off the discharge lines to the pump. Shut off the compressed air supply, bleed the pressure from the pump and disconnect the air supply line from the pump. Drain any remaining liquid from the pump.

Step #1: See the pump assembly drawing and the diaphragm servicing illustration.

Using a 1/2" wrench or socket, remove the 16 capscrews (item 9) that fasten the manifolds (items 19 & 20) to the outer chambers (item 13).

Step #2: Removing outer chambers.

Using a 1/2" wrench or socket, remove the 16 capscrews (item 10), that fasten the outer chambers (item 13), diaphragms (item 14) and intermediate (item 5) together.

Step #3: Removing the diaphragms and diaphragm plates.

Use a 7/8" wrench or six point socket to remove the outer diaphragm plate assemblies (item 24), diaphragms (item 14) and inner diaphragm plates (item 23) from the diaphragm rod (item 27) by turning counterclockwise. Inspect the diaphragm for cuts, punctures, abrasive wear or chemical attack. Replace the diaphragms if necessary. **DO NOT USE A WRENCH ON THE DIAPHRAGM ROD. FLAWS ON THE SURFACE MAY DAMAGE BEARINGS AND SEALS.**

Step #4: Assembling the diaphragm and diaphragm plates to the diaphragm rod.

Push the threaded stud of one outer diaphragm plate assembly through the center of one diaphragm and through one inner diaphragm plate. Install the diaphragm with the natural bulge facing away from the diaphragm rod and make sure the radius on the inner diaphragm plate is towards the diaphragm, as indicated on the diaphragm servicing illustration. Thread the assembly onto the diaphragm rod, leaving loose.

Step #5: Installing the diaphragm and rod assembly to the pump.

Make sure the bumper (item 6) is installed over the diaphragm rod. Insert rod into pump.

On the opposite side of the pump, pull the diaphragm rod out as far as possible. Make sure the second bumper is installed over the diaphragm rod.

Push the threaded stud of the other outer diaphragm plate assembly through the center of the other diaphragm and through the other inner diaphragm plate. Make sure the radius on the inner diaphragm plate is towards the diaphragm. Thread the assembly onto the diaphragm rod. Use a 7/8" wrench or socket to hold one outer diaphragm plate. Then, use a torque wrench to tighten the other outer diaphragm plate to the diaphragm rod to 500 in. lbs. (56.5 Newton meters).

Align one diaphragm with the intermediate and install the outer chamber to the pump using the 8 capscrews. Tighten the opposite diaphragm plate until the holes in the diaphragm align with the holes in the intermediate. Then, install the other outer chamber using the 8 capscrews.

Step #6: Reinstall the manifolds to the pump using the 16 capscrews.

The pump is now ready to be reinstalled, connected and returned to operation.

OVERLAY DIAPHRAGM SERVICING

The overlay diaphragm (item 15) is designed to fit over the exterior of the standard diaphragm (item 14).

Follow the same procedures described for the standard diaphragm for removal and installation, except tighten the outer diaphragm plate assembly, diaphragms and inner diaphragm plate to the diaphragm rod to 500 in. lbs. (56.5 Newton meters).

One-Piece Bonded DIAPHRAGM SERVICING (Bonded PTFE with integral plate)

The one-piece bonded diaphragm (item 14) has a threaded stud installed in the integral plate at the factory. The inner diaphragm plate has a through hole instead of a threaded hole.



! IMPORTANT

Read these instructions completely, before installation and start-up. It is the responsibility of the purchaser to retain this manual for reference. Failure to comply with the recommendations stated in this manual will damage the pump, and void factory warranty.

Place the inner plate over the diaphragm stud and thread the first diaphragm / inner plate onto the diaphragm rod only until the inner plate contacts the rod. Do not tighten. A small amount of grease may be applied between the inner plate and the diaphragm to facilitate assembly.

Insert the diaphragm / rod assembly into the pump and install the outer chamber. Turn the pump over and thread the second diaphragm / inner plate onto the diaphragm rod. Turn the diaphragm until the inner plate contacts the rod and hand tighten the assembly. Continue tightening until the bolt holes align with the inner chamber holes. **DO NOT LEAVE THE ASSEMBLY LOOSE.**

Pilot Valve Servicing, Assembly Drawing & Parts List

PILOT VALVE ASSEMBLY PARTS LIST

ITEM	PART NUMBER	DESCRIPTION	QTY
4	095-110-000	Pilot Valve Assembly	1
4-A	095-095-157	Valve Body	1
4-B	755-052-000	Sleeve (With O-rings)	1
4-C	560-033-360	O-ring (Sleeve)	6
4-D	775-055-000	Spool (With O-rings)	1
4-E	560-023-360	O-ring (Spool)	3
4-F	675-037-080	Retaining Ring	1

FOR PUMPS WITH CAST IRON CENTER SECTION

ITEM	PART NUMBER	DESCRIPTION	QTY
4	095-110-558	Pilot Valve Assembly	1
4-A	095-095-558	Valve Body (includes all other items used on 095-110-000)	1

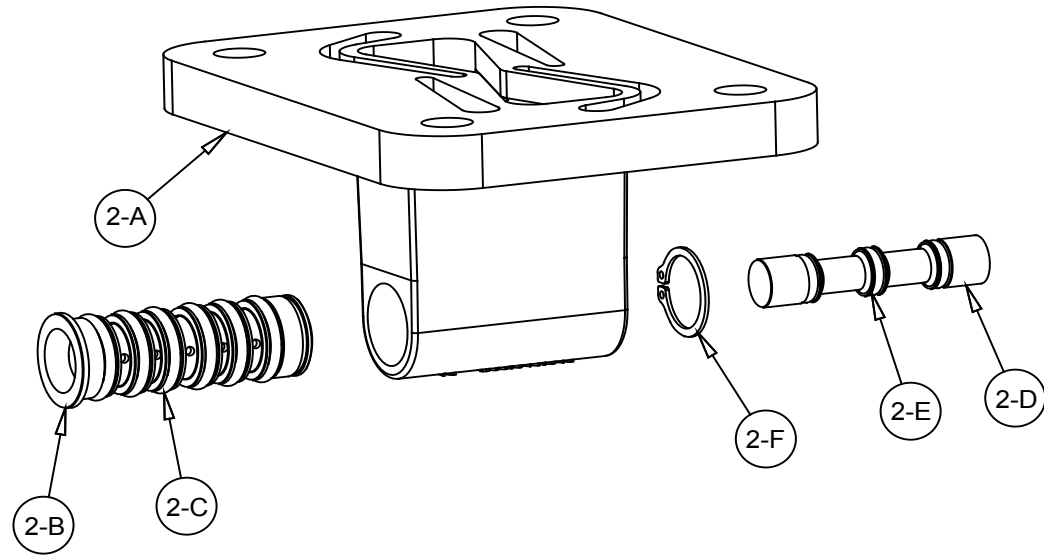

PILOT VALVE SERVICING

To service the pilot valve first shut off the compressed air supply, bleed the pressure from the pump, and disconnect the air supply line from the pump.

STEP #1: See pump assembly drawing.

Using a 1/2" wrench or socket, remove the four capscrews (item 11). Remove the air inlet cap (item 8) and air inlet gasket (item 18). The pilot valve assembly (item 4) can now be removed for inspection and service.

STEP #2: Disassembly of the pilot valve.

Remove the pilot valve spool (item 4-D). Wipe clean and inspect spool and o-rings for dirt, cuts or wear. Replace the o-rings and spool if necessary.

Remove the retaining ring (item 4-F) from the end of the sleeve (item 4-B) and remove the sleeve from the valve body (item 4-A). Wipe clean and inspect sleeve and o-rings for dirt, cuts or wear. Replace the o-rings and sleeve if necessary.

STEP #3: Re-assembly of the pilot valve.

Generously lubricate outside diameter of the sleeve and o-rings. Then carefully insert sleeve into valve body. Take CAUTION when inserting sleeve, not to shear any o-rings. Install retaining ring to sleeve. Generously lubricate outside diameter of spool and o-rings. Then carefully insert spool into sleeve. Take CAUTION when inserting spool, not to shear any o-rings. Use BP-LS-EP-2 multipurpose grease, or equivalent.

STEP #4: Re-install the pilot valve assembly into the intermediate.

Be careful to align the ends of the pilot valve stem between the plunger pins when inserting the pilot valve into the cavity of the intermediate.

Re-install the gasket, air inlet cap and capscrews. Connect the air supply to the pump. The pump is now ready for operation.

ACTUATOR PLUNGER SERVICING

To service the actuator plunger first shut off the compressed air supply, bleed the pressure from the pump, and disconnect the air supply line from the pump.

Step #1: See PUMP ASSEMBLY DRAWING.

Using a 1/2" wrench or socket, remove the four capscrews (items 11). Remove the air inlet cap (item 8) and air inlet gasket (item 18). The pilot valve assembly (item 4) can now be removed.

Step #2: Inspect the actuator plungers.

See ILLUSTRATION AT RIGHT.

The actuator plungers (items 25) can be reached through the pilot valve cavity in the intermediate assembly (item 5).

Remove the plungers (item 25) from the bushings (item 7) in each end of the cavity. Inspect the installed o-ring (items 21) for cuts and/or wear. Replace the o-rings if necessary. Apply a light coating of grease to each o-ring and re-install the plungers in to the bushings. Push the plungers in as far as they will go.

To remove the bushings (item 7), first remove the retaining rings (item 26) by using a flat screwdriver.

NOTE: It is recommended that new retaining rings be installed.

Step #3: Re-install the pilot valve assembly into the intermediate assembly.

Be careful to align the ends of the stem between the plungers when inserting the stem of the pilot valve into the cavity of the intermediate.

Re-install the gasket (item 18), air inlet cap (item 8) and capscrews (item 11).

Connect the air supply to the pump. The pump is now ready for operation.

ACTUATOR PLUNGER SERVICING

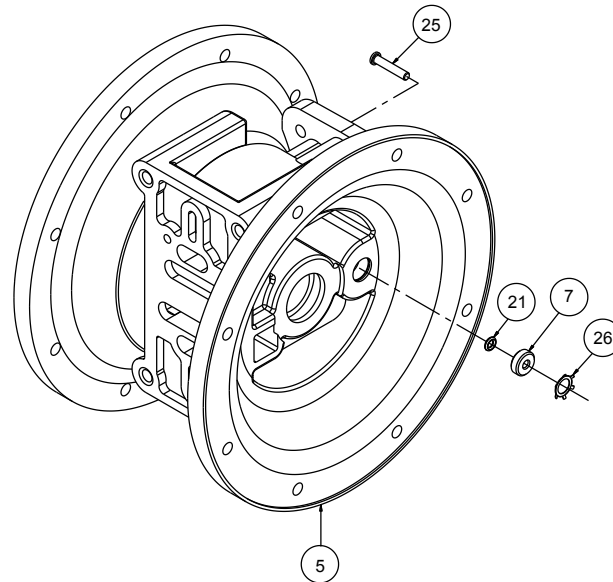

! IMPORTANT

Read these instructions completely, before installation and start-up. It is the responsibility of the purchaser to retain this manual for reference. Failure to comply with the recommendations stated in this manual will damage the pump, and void factory warranty.

CHECK VALVE SERVICING

Before servicing the check valve components, first shut off the suction line and then the discharge line to the pump. Next, shut off the compressed air supply, bleed air pressure from the pump, and disconnect the air supply line from the pump. Drain any remaining fluid from the pump. The pump can now be removed for service.

To access the check valve components, remove the manifold (item 20 or item 19 not shown). Use a $\frac{1}{2}$ " wrench or socket to remove the fasteners. Once the manifold is removed, the check valve components can be seen.

Inspect the check balls (items 2) for wear, abrasion, or cuts on the spherical surface. The check valve seats (item 29) should be inspected for cuts, abrasive wear, or embedded material on the surfaces of both the external and internal chambers. The spherical surface of the check balls must seat flush to the surface of the check valve seats for the pump to operate to peak efficiency. Replace any worn or damaged parts as necessary.

Re-assemble the check valve components. The seat should fit into the counter bore of the outer chamber.

The pump can now be reassembled, reconnected and returned to operation.

METALLIC SEATS

Two o-rings (item 22) are required for metallic seats.

Check Valve Drawing

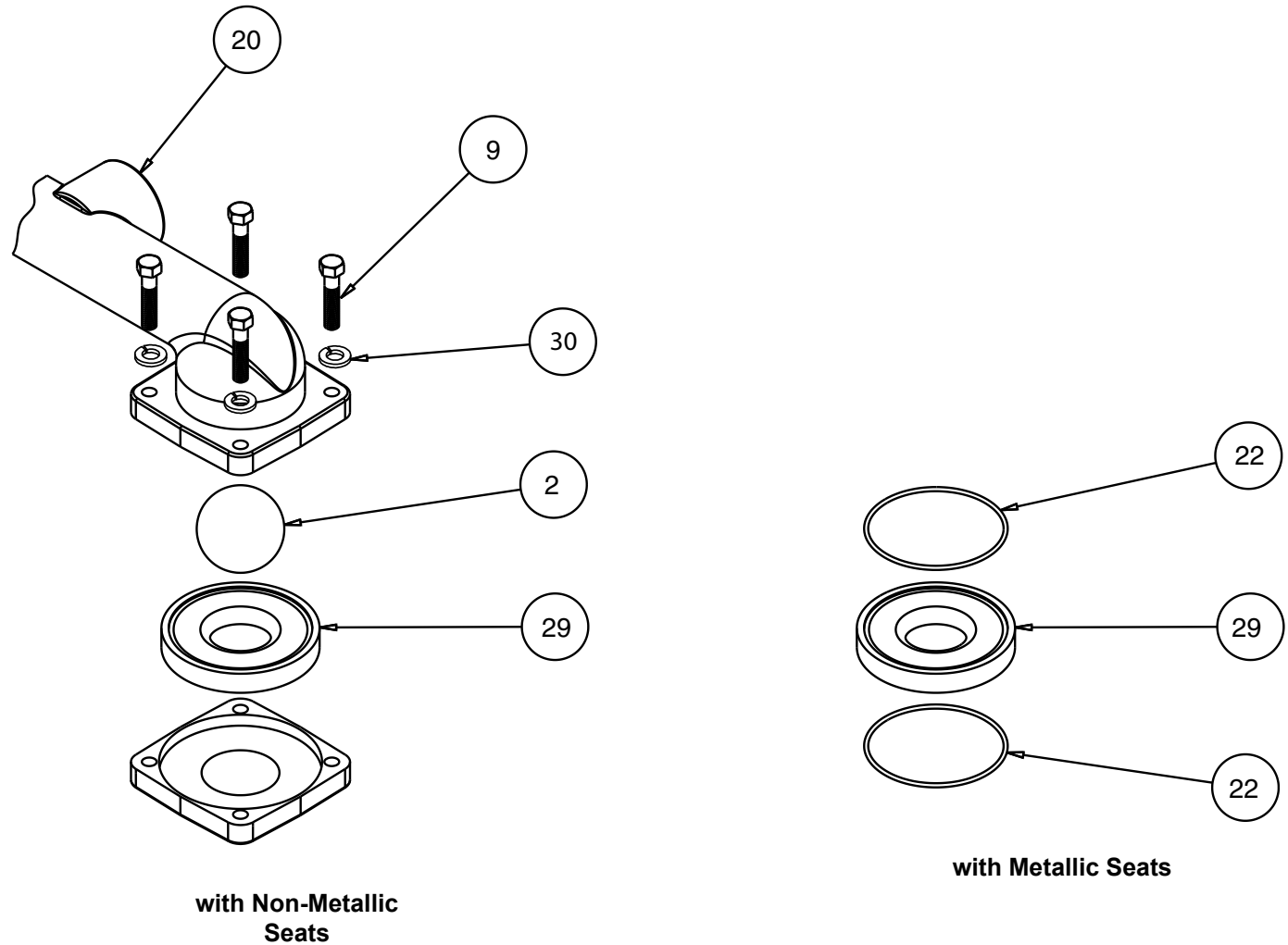

Optional Muffler Configurations, Drawing

OPTION 0

530-028-550 Encapsulated Muffler uses (1) *
Cap and (4) 710-015-115 Self Tapping Screw
to hold it in place.

OPTION 1

530-027-000 Sound Dampening Muffler
screws directly into the Air Valve body.
This muffler is equipped with a porous
plastic element.

OPTION 2

530-010-000 Mesh Muffler screws
directly into the Air Valve Body. This
muffler is equipped with a metal element.

* Note: Cannot be used with Air Valve
Assembly 031-179-000 used with
cast iron centers.

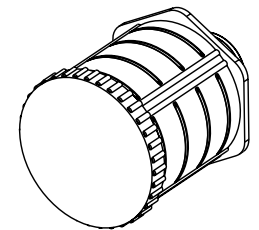
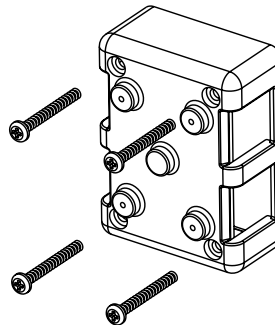
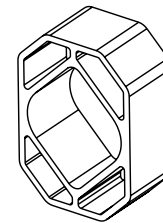
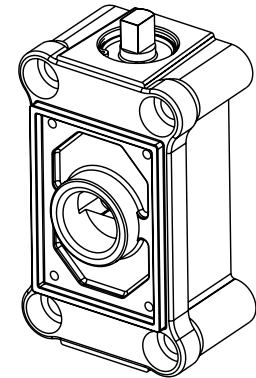

OPTION 6

530-033-000 Metal Muffler screws
directly into the Air Body.

 **ATEX Compliant**

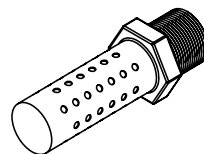

Option 6

Option 0

Option 1 and 2

PUMPING HAZARDOUS LIQUIDS

When a diaphragm fails, the pumped liquid or fumes enter the air end of the pump. Fumes are exhausted into the surrounding environment. When pumping hazardous or toxic materials, the exhaust air must be piped to an appropriate area for safe disposal. See illustration #1 at right.

This pump can be submerged if the pump materials of construction are compatible with the liquid being pumped. The air exhaust must be piped above the liquid level. See illustration #2 at right. Piping used for the air exhaust must not be smaller than 1" (2.54 cm) diameter. Reducing the pipe size will restrict air flow and reduce pump performance. When the pumped product source is at a higher level than the pump (flooded suction condition), pipe the exhaust higher than the product source to prevent siphoning spills. See illustration #3 at right.

CONVERTING THE PUMP FOR PIPING THE EXHAUST AIR

The following steps are necessary to convert the pump to pipe the exhaust air away from the pump.

Remove the muffler (item 31). The air distribution valve (item 1) has 1" NPT threads for piped exhaust.

IMPORTANT INSTALLATION

NOTE: The manufacturer recommends installing a flexible conductive hose or connection between the pump and any rigid plumbing. This reduces stresses on the molded threads of the air exhaust port. Failure to do so may result in damage to the air distribution valve body.

Any piping or hose connected to the pump's air exhaust port must be conductive and physically supported. Failure to support these connections could also result in damage to the air distribution valve body.

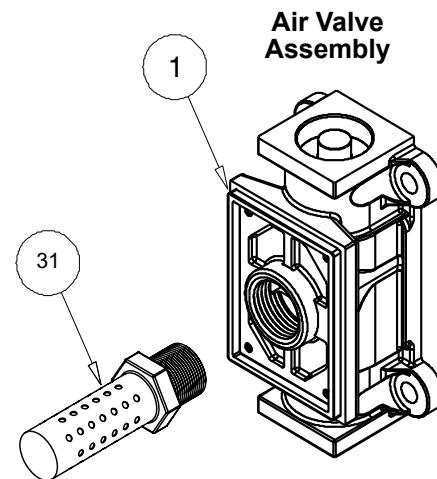

On ATEX compliant units the pump comes equipped with a standard metal muffler

CONVERTED EXHAUST ILLUSTRATION

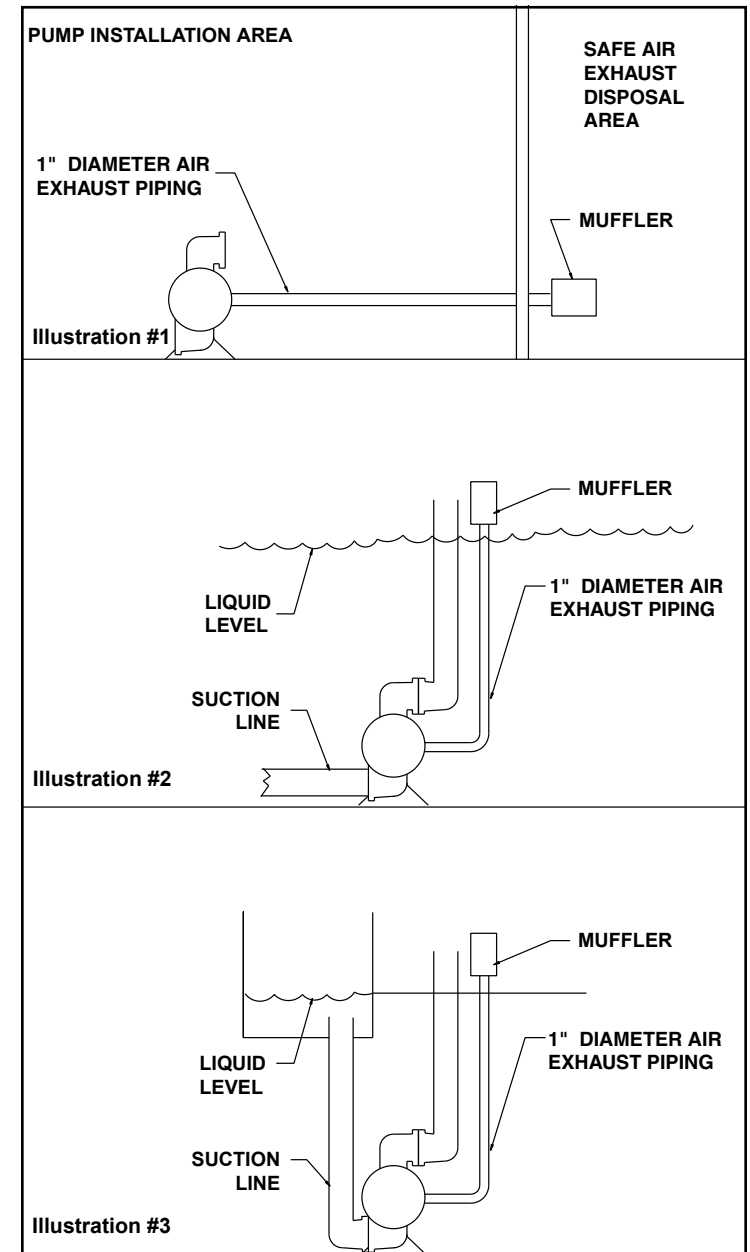

Pulse Output Kit Drawing

PULSE OUTPUT KIT OPTION

This pump can be fitted with a Pulse Output Kit. This converts the mechanical strokes of the pump to an electrical signal which interfaces with the RuppTech® Stroke Counter/ Batch Controller or user control devices such as a PLC.

The Pulse Output Kits mount directly onto the Muffler Cap on the Air Distribution Valve Assembly or onto the air valve and senses each stroke of the main spool.

Consult the factory for further information and availability.

Pulse Output Kits

475-244-001	10-30 VDC
475-244-002	110/220 VAC
475-244-003	10-30VDC, 110VAC and 220 VAC

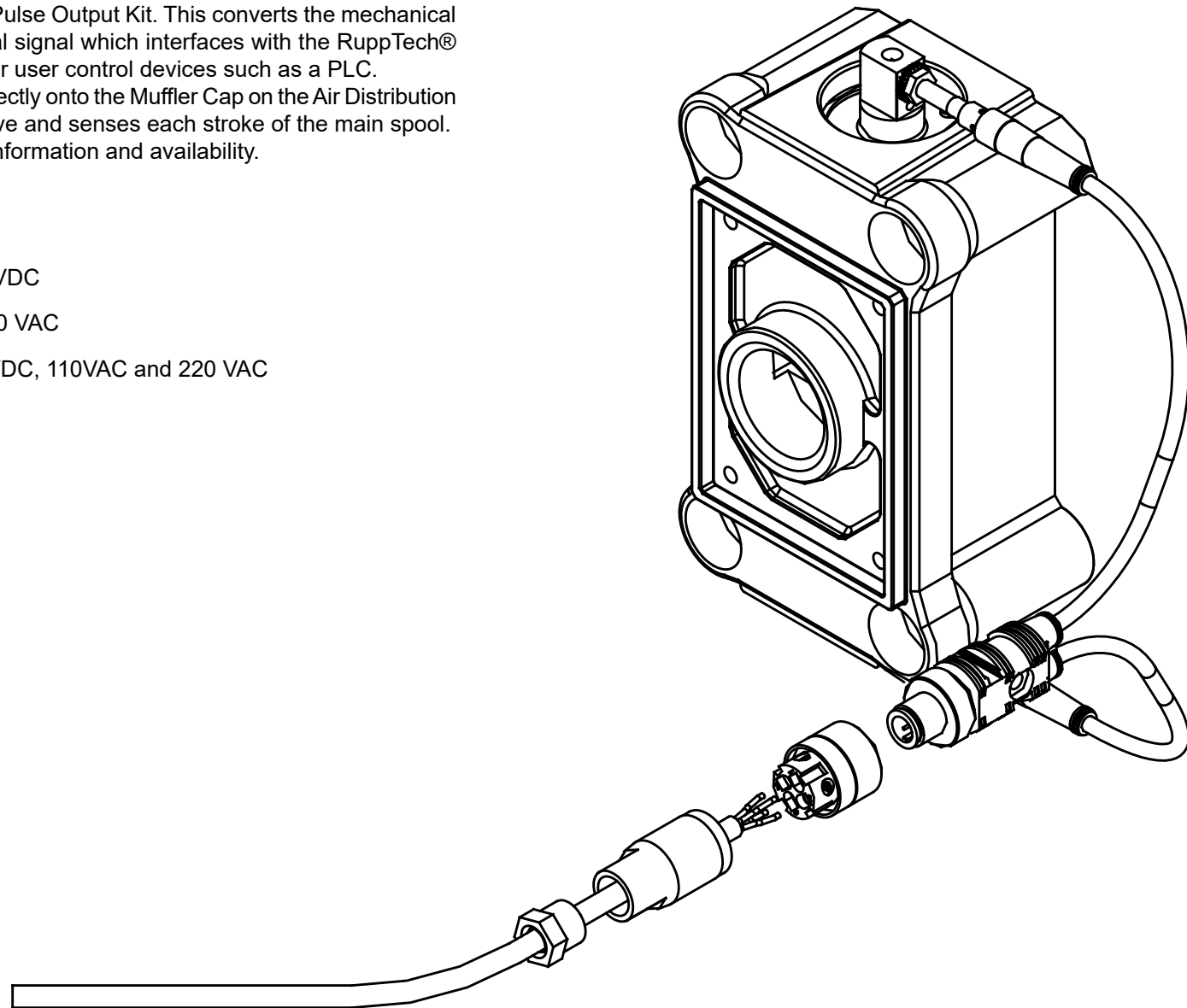

Grounding The Pump

To be fully groundable, the pumps must be ATEX Compliant. Refer to pump data sheet for ordering.

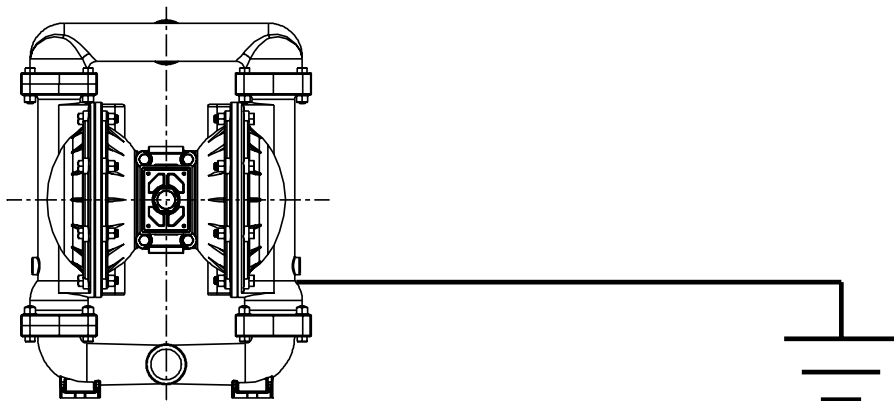
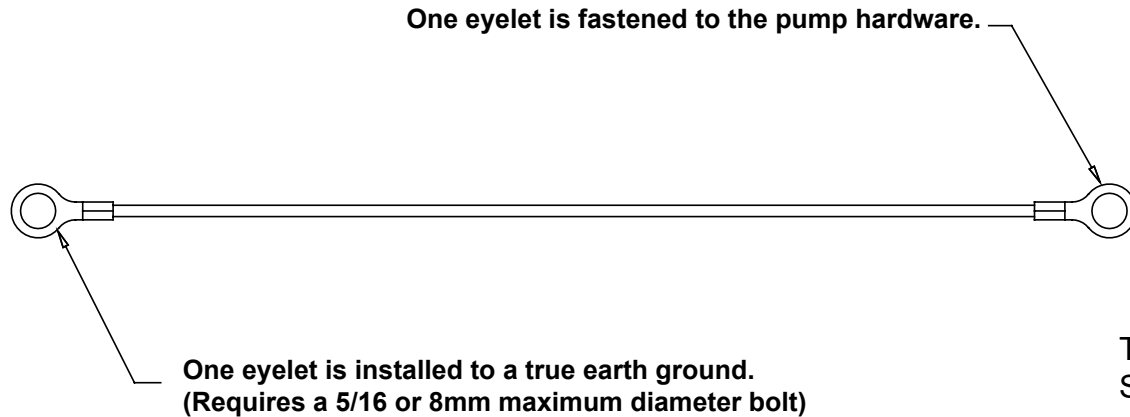

	! WARNING
	<i>Take action to prevent static sparking. Fire or explosion can result, especially when handling flammable liquids. The pump, piping, valves, containers or other miscellaneous equipment must be grounded.</i>

Declaration of Conformity

Declaration of Conformity

BRUIN PUMPS

Declaration of Conformity

BRUIN INSTRUMENT CORPORATION • 9001 20th Street T6P1K8 • Edmonton, Alberta CANADA

Certifies that Air-Operated Double Diaphragm Pump G and S Series Metallic Pumps comply with the European Community Directive 2006/42/EC on Machinery, according to Annex VIII.

This product has used Harmonized Standard EN 809, Pumps and Pump Units for Liquids - Common Safety Requirements, to verify conformance.

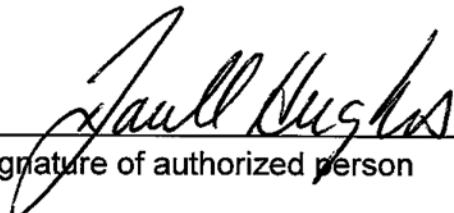

Signature of authorized person

Darrell Hughes

Printed name of authorized person

Revision Level: E

October 20, 2005

Date of issue

V.P. Sales.

Title

January, 17 2011

Date of revision



Declaration of Conformity

Declaration of Conformity

BRUIN PUMPS



EC / EU Declaration of Conformity

The objective of the declaration described is in conformity with the relevant Union harmonisation legislation: Directive 94/9/EC (until April 19, 2016) and Directive 2014/34/EU (from April 20, 2016).

BRUIN INSTRUMENT CORPORATION • 9001 20th Street T6P1K8 • Edmonton, Alberta CANADA

Air and Gas Operated Double Diaphragm Pumps
Technical File No.: 203104000-1410/MER

Applicable Standard:
EN13463-1: 2001,
EN13463-5: 2003

EC Type Examination Certificate No. Pumps: KEMA 09ATEX0071 X
DEKRA Certification B.V. (0344)
Meander 1051
6825 MJ Arnhem
The Netherlands

I M1 c
II 1 G c T5
II 1 D c T100°C
II 2 G c T5
II 2 G c T100°C

Harmonised Standards:
EN13463-1: 2009
EN13463-5: 2011
EN60079-25:2010

The harmonised standards have been compared to the applicable standards used for certification purposes and no changes in the state of the art technical knowledge apply to the listed equipment.

DATE/APPROVAL/TITLE:
26 May 2016
Revision:

Paul Hughes V.P. Sales